

MAKING A PRINTED CIRCUIT BOARD

INTRODUCTION

Most electronic circuits produced by industry use printed circuit boards (PCBs) because they are reliable. The boards are made from glass reinforced plastic (GRP) and have conductive copper tracks instead of wires printed on one side. Holes are drilled through the board to take components which are connected to the copper tracks by soldering.

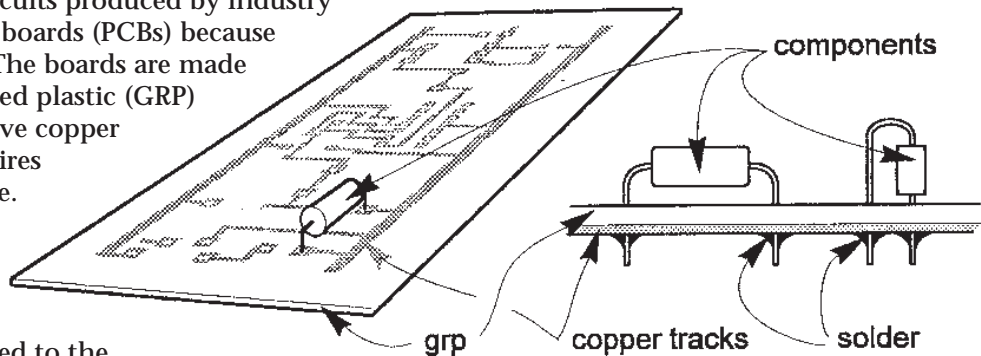

To start to make your PCB, you'll need:

- A PCB mask of your circuit.
- A piece of photo-resist board.

CUTTING THE BOARD

When you cut the photo-resist board to the right size determined by your mask, it is advisable to leave at least 4 mm around the edge of the mask for final trimming. Always leave the black film on the board and cut it with a hacksaw with the black film side uppermost.

It is also best to cut from both ends of the board to prevent it from cracking. It is not essential but you can smooth the edges with a file.

When you are cutting the board, tape the mask on the board and mark the corners of the PCB on the mask with a marker pen. Try hard not to touch the sensitised surface of the film and make sure you don't get dust between the PCB and the mask.

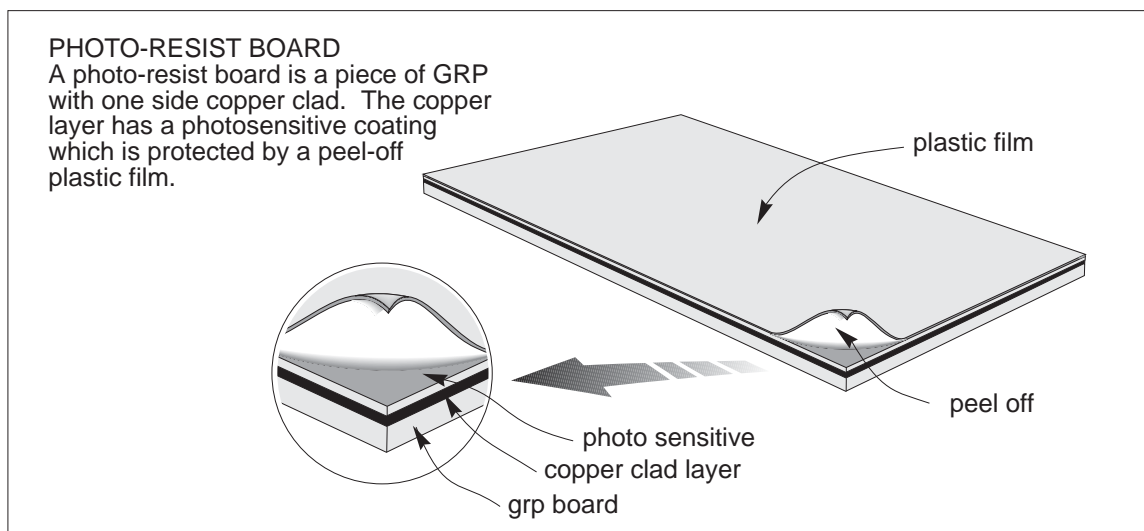

MAKING THE PCB MASK

The PCB mask can be produced by photocopying the PCB diagram onto clear acetate sheet. The PCB diagram may be hand drawn or printed out from a computer.

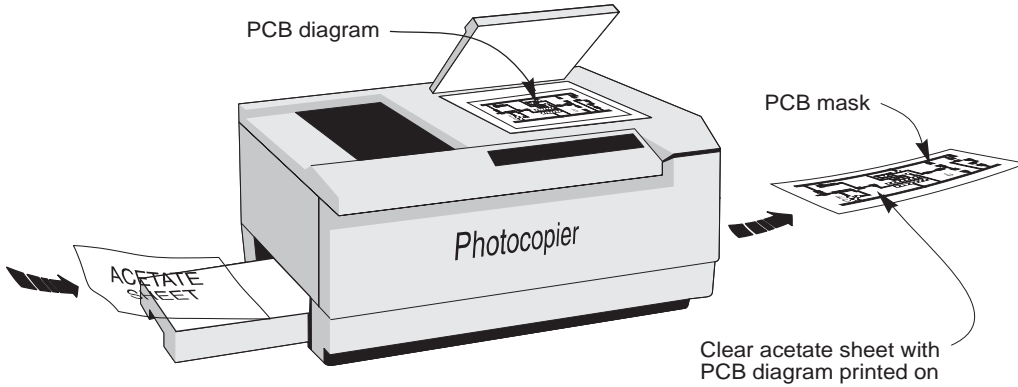

DEVELOPING THE CIRCUIT

- Cut the PCB mask from the acetate sheet to fit the photo-resist board.
- Peel off the protective plastic film and place the PCB mask on the exposed surface of the board.

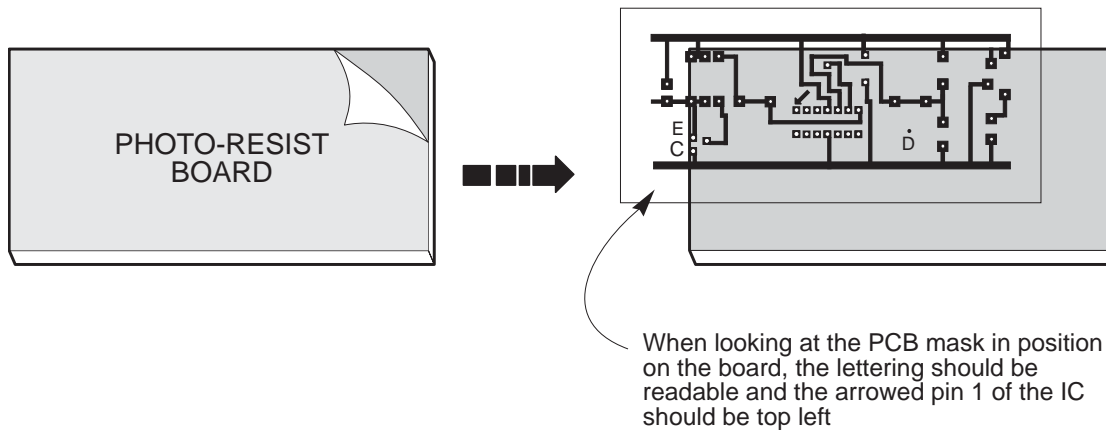

CAUTION:

The next stages in PCB manufacture must be organised safely.

- 1 Ultra-Violet (UV) light can damage eyes. Wear goggles.
- 2 Developer and ferric chloride are corrosive. Wear goggles, rubber gloves and apron.

NOTE: A non-corrosive Universal Developer is recommended and available from RS (stock number 690-849). Safer alternatives to ferric chloride are available.

- Place the board, with the PCB mask in contact, face down on a UV light box. Close the light box and switch on for two and a half minutes.
- Remove the board and film from the light box and immerse in developer to remove photo-sensitive layer. Agitate the board for 2-3 minutes until the circuit is clearly visible. The edges of the tracks must be clean.

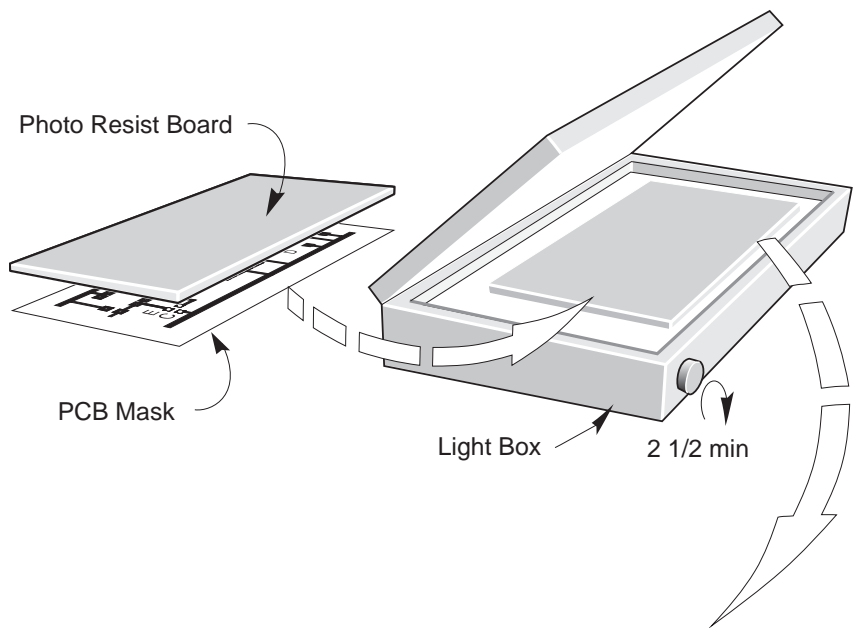

- Remove the board from the developer and wash it under a tap.

- Place the board in a bubble etch tank containing ferric chloride to etch (remove) the unwanted copper. Inspect it at intervals and remove it from the tank when the etching is complete. This takes about 15-45 minutes depending on the strength and temperature of the solution.

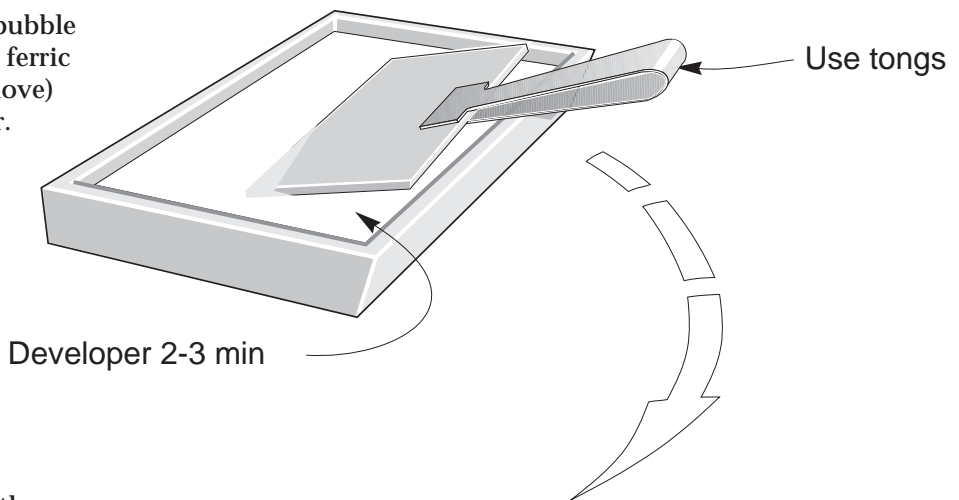

- Wash the board and then use solvent or a PCB eraser cleaner (RS stock number 555-308) to remove film from the copper tracks.

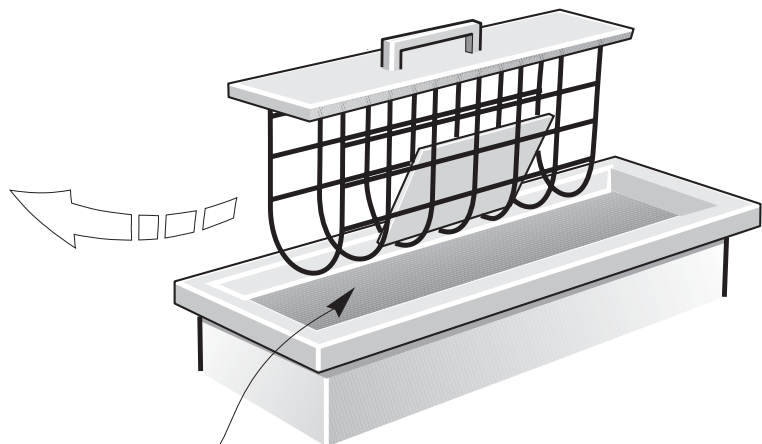
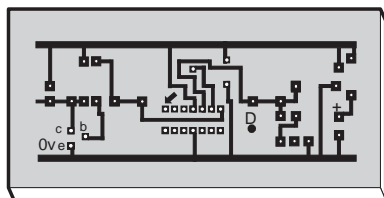

Bubble etch 15-45 min

QUALITY CHECK

- After your PCB has been etched, use a magnifier to check for bridges between the tracks.

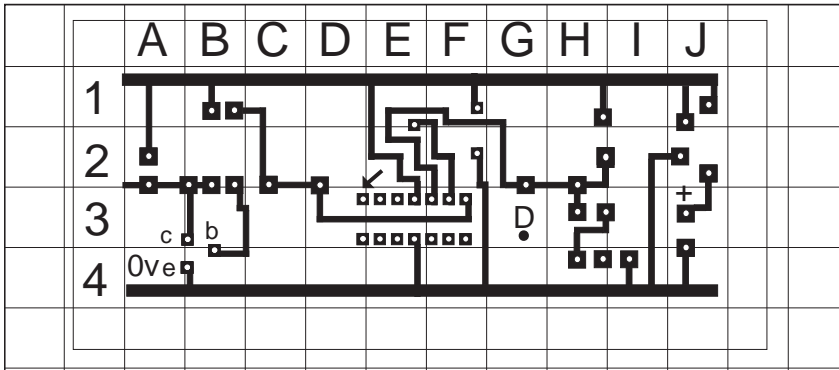

- Make a record of the position of each bridge in the table on the next page - here's an example.

No.	Position	Description of fault found	Date rectified	Checked
1	E3	Bridge between pins 1 & 2 on IC	11/3/93	

- Remove the bridge carefully using a craft knife and enter the date in the table.
- Follow the same procedure for broken tracks and repair these by soldering a piece of wire across the gap.

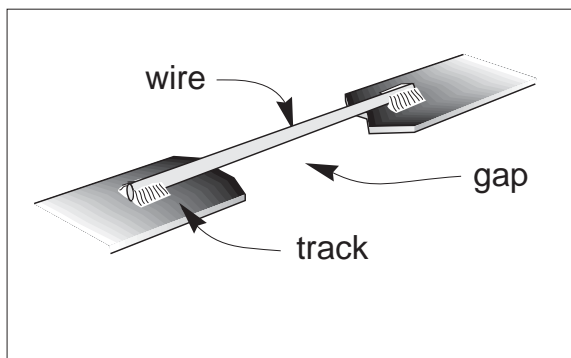

Copy and complete this table.

No.	Position	Description of fault found	Date rectified	Checked

DRILLING HOLES

You need to drill holes to mount the components and connect wires to the board. Use a high speed 1.0 mm drill for the holes to mount components. Also drill any holes needed for mounting the completed board.

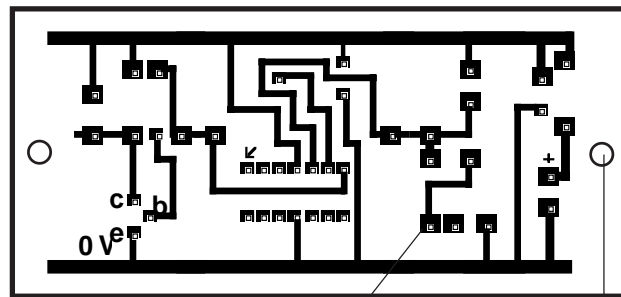

Component hole

Mounting hole