

THE PROGRAMMABLE LOGIC CONTROLLER (PLC)

PROGRAMMABLE LOGIC CONTROLLERS

A PLC is a very flexible electronic unit that can be programmed from a computer to carry out a very wide range of control tasks. PLCs originated in 1968 at General Motors where engineers had the idea of creating a single type of controller that could be used for many different operations. Up until that time, different machines used their own purpose-designed control systems.

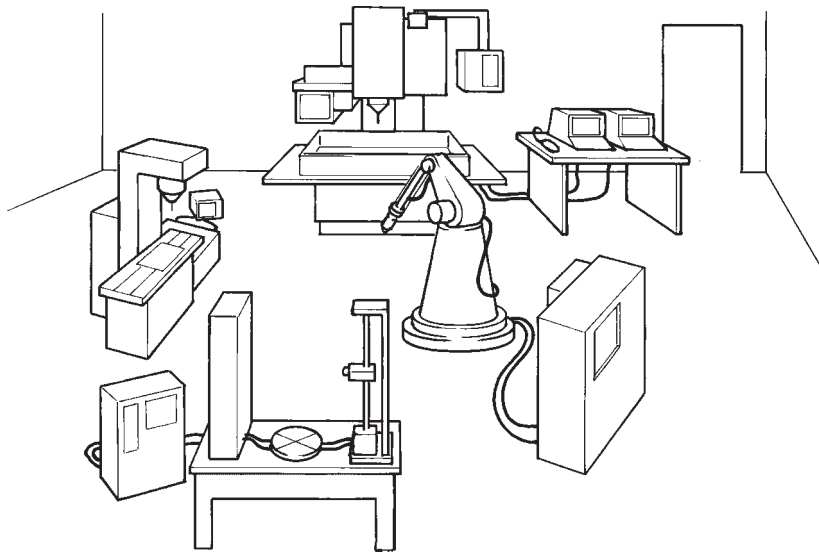

For example, injection moulding machines were (and many still are) designed with custom-built process controllers to control the sequence of mechanical movements and the plastics temperature. Now, it is possible to provide injection moulding machines and many other entirely different machines with a single type of PLC which is programmed for the particular requirements of each machine.

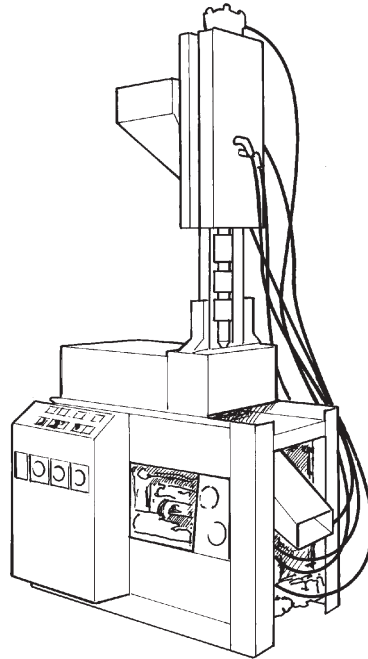

A typical commercial PLC is a small free-standing unit with a number of inputs (connected to switches and sensors) and a number of output switches used, for example, to turn on a motor or heater. At the heart of the PLC is a microprocessor that stores a programme (entered via a computer) and instructs the output switches to turn on and off in a certain order - but only according to the state of the input(s). For example, the programme might tell the PLC to switch a motor on and off in a certain sequence but only when an (input) microswitch switch is closed. This is a typical safety measure to ensure that a machine will not run if a guard is left in the open position.

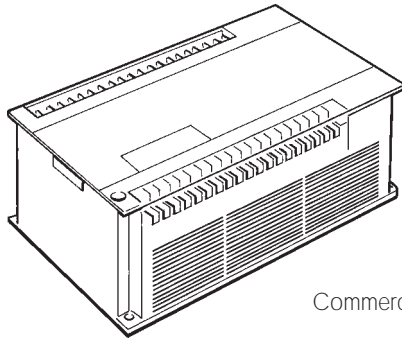

Commercial PLC

PLCs can be built up into more complex modular systems from a number of smaller 'building blocks' for larger control applications. Most commercial PLCs also incorporate heavy-duty relay switches as outputs so that they can be used for switching large currents without any additional components.

Most commercial PLCs are programmed via a computer (or hand-held device) using *ladder logic* notation. This is so called because a control programme appears on the computer screen as a series of horizontal programme lines one on top of another.

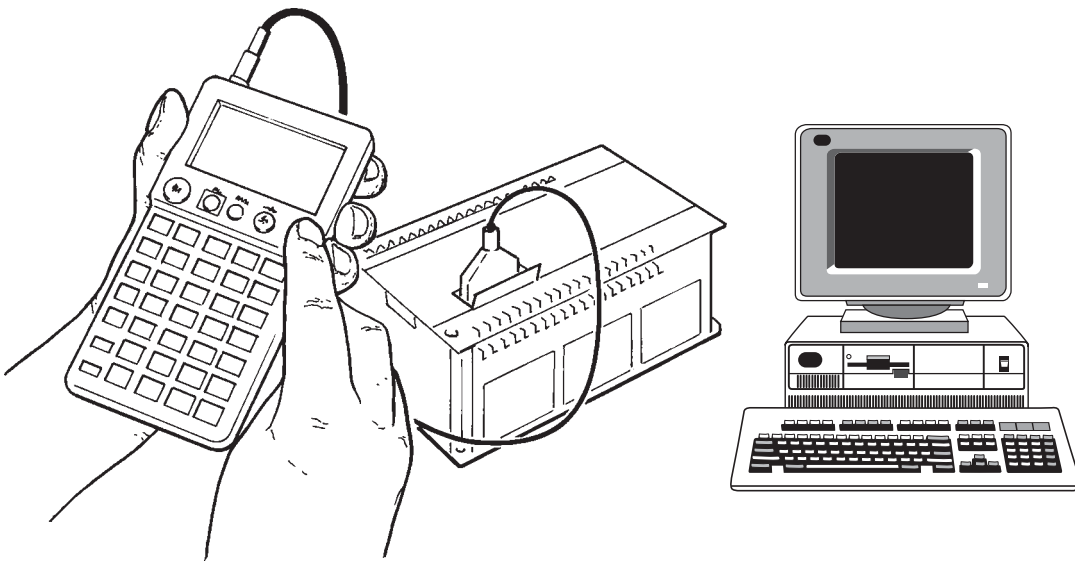

Ladder logic is sometimes described as *iconographic* programming because the instructions are built up on each ladder 'step' as a series of *icons* - pictures or symbols each having a meaning. For example 'I' stands for input and 'O' for output switch.

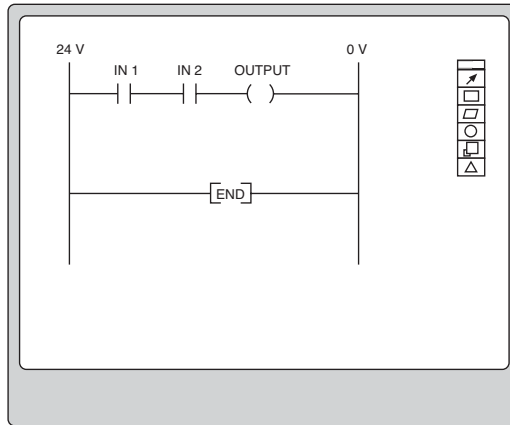

An example of a very simple ladder logic programme is shown. The PLC controls a motor which is turned on when, and only when, the two input switches are both closed.

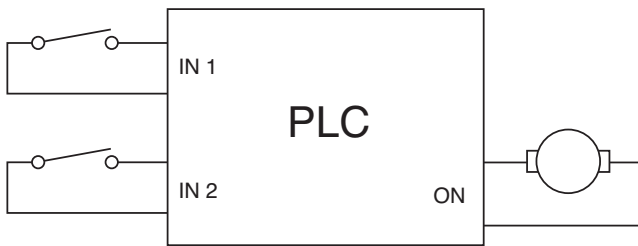

Many more programming lines can be added using these symbols and others. Each line is in fact very similar to a circuit diagram. Reading from left to right, you have the positive supply rail connected through two inputs (switches) to an output that returns to the 0 V rail.

