

INVESTIGATING THE BIPOLAR TRANSISTOR

Most of the transistors you will be using in school are of the bipolar type. 'Bipolar' describes their basic construction, and examples include the BC108 and the BFY 51.

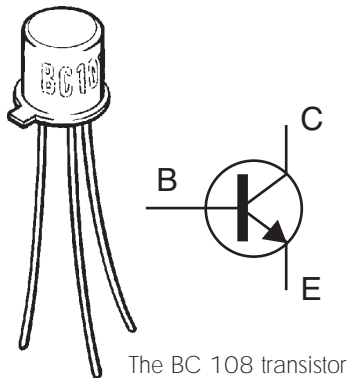

Bipolar transistors amplify current. A small current flowing to the base of the transistor causes a much larger current to flow collector to emitter.

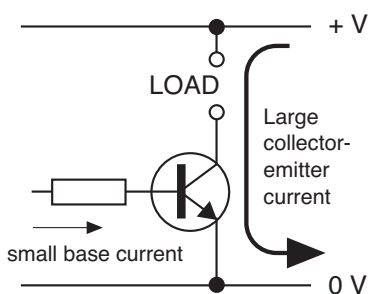

A transistor is sometimes described as an electronic switch because it can be used to switch a large LOAD* current ON or OFF.

*Whatever is switched on or off is called the load.

A multimeter can be used to investigate current flow in a bipolar transistor using the following method:

- Set up a BFY 51 transistor in a prototyping board as shown. The load to be switched on is a low wattage 6V filament bulb.

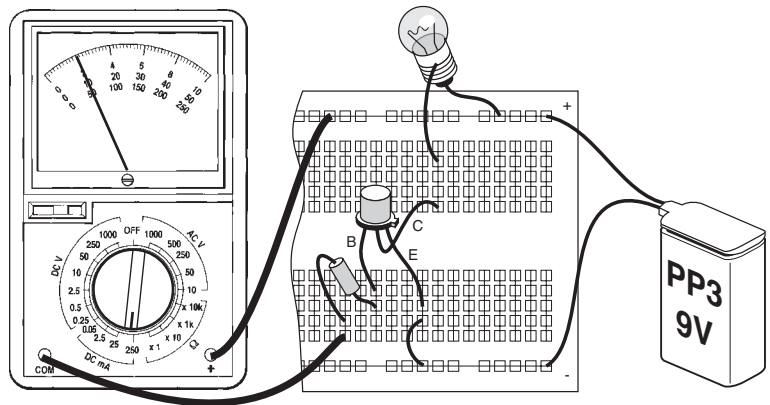

- Set the multimeter range to DC 250 mA. Making sure the probes are the correct way around (red to +ve), place them on the positive supply rail and the base resistor (2.2 kΩ). Base current will flow through the meter and cause the transistor to pass collector-emitter current and light up the bulb. Record the amount of base current that flows when this happens.
- Now place the multimeter probes between the collector (c) and one side of the bulb. Provide base current to the transistor by connecting one end of the base resistor to the positive supply rail as shown in the diagram below. The bulb lights up and the meter shows the amount of current flowing through the bulb. Record this current.

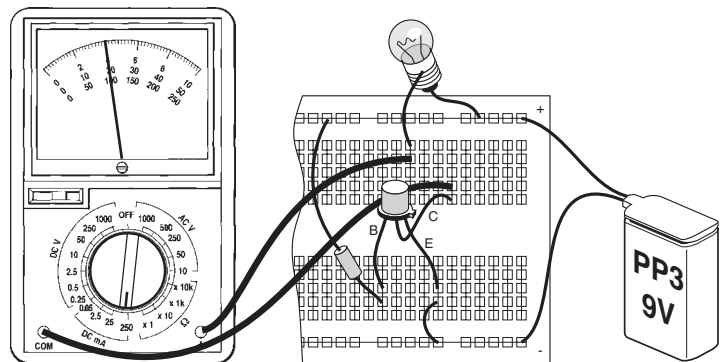

You will see from this experiment that the amount of collector-emitter current which flows is much greater than the base current which causes it. If the collector-emitter current of a transistor is - say - 50 times greater than the base current, we say the transistor has a gain of 50. The symbol for gain is h_{FE}

Before a bipolar transistor passes any collector-emitter current, the voltage at its base has to be at least 0.6V. This base voltage can be controlled using a sensor, such as a thermistor or an LDR, as part of a potential divider. (See Study File 1.)

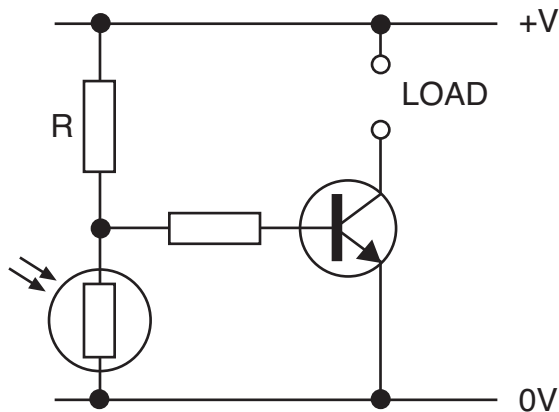

DARLINGTON PAIR

The sensitivity of a transistor switching circuit may be greatly increased by using two transistors wired together to form a Darlington pair as shown below.

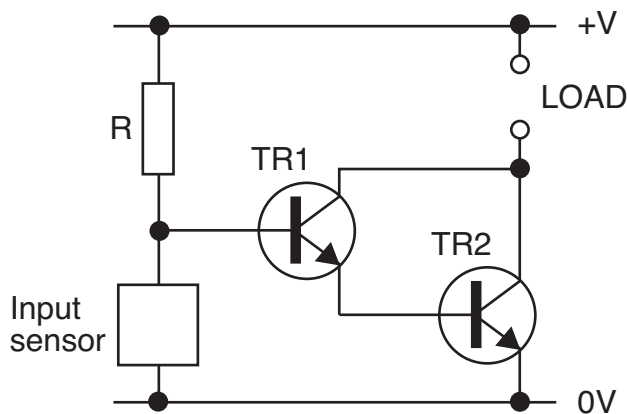

The voltage at the base of TR1 has to be at least 1.2 volts before a current flows in the load. The first transistor TR1 is chosen with a high value of h_{FE} whilst TR2 is chosen to handle a large load current. The circuit is often referred to as a Darlington driver.

The overall current gain of a Darlington is the product of the individual gains of the two transistors. For example if TR1 has $h_{FE} = 250$ and TR2 has $h_{FE} = 40$ then

$$\begin{aligned}\text{Overall gain} &= 40 \times 250 \\ &= 10000\end{aligned}$$

For electronic systems that have several outputs it becomes inconvenient to wire a pair of transistors to each output. For this reason Darlington drivers are available in IC packages with up to eight Darlingtons on a single IC.