

QUALITY CONTROL EXERCISE

Most people enjoy a puzzle because it exercises their skills. Puzzles have provided enjoyment from the earliest civilisations through to more recent times - they were particularly popular during the 19th century. Most puzzles have only one solution, but this one - the Soma Cube - has many. Its inventor is the Danish puzzle expert, Pat Hein.

THE SOMA CUBE

These are the seven pieces that make up the Soma Cube. Notice that the first piece is made up of three cubes while the rest are made up of four cubes each - the original three cubes plus one other cube in different positions.

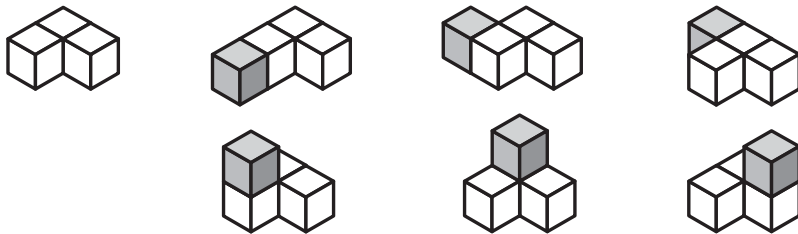

You will need:

- Materials - 400 mm length of 12 mm x 12 mm softwood.
- PVA wood glue.
- Polyurethane varnish.
- Tools:
 - Tenon saw
 - Try square
 - Ruler
 - Pencil.

There are several ways to make the pieces. One way is to mark off the length of 12 mm x 12 mm softwood at 12 mm intervals and cut off individual cubes. How many will you need?

To save time, you could cut some two cube and three cube lengths. How many of these would you need?

The method of producing lengths or cubes is neither fast nor accurate unless you are skilled.

To improve quality you could use a special tool or make a jig to ensure that each piece is the same size. A mitre saw with a length gauge is an example of a tool that would assist here.

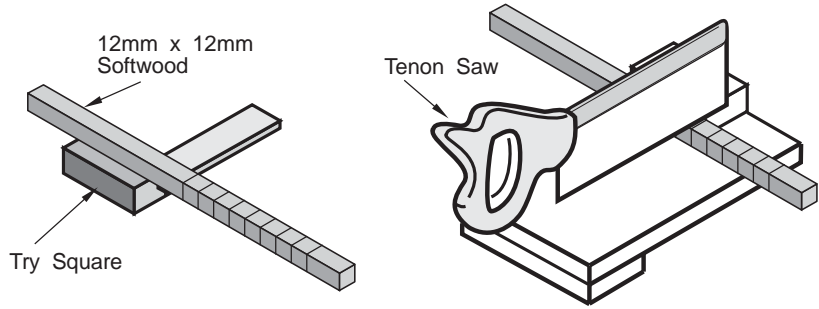

EVALUATION

Try assembling the pieces to make the Soma Cube. There are many ways to do this. It is also possible to make a Soma Cube that will hold together when balanced at one point. Here are two solutions:

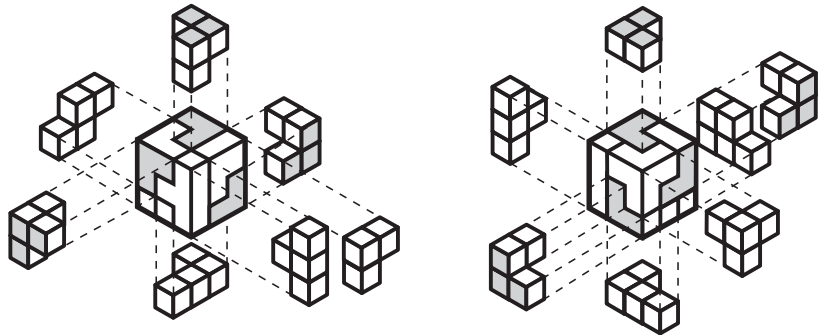

1. Select the piece with this shape and measure lengths A and B.

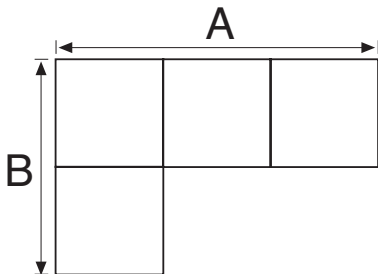

The tolerance on dimension A is ± 1 mm. Each cube is 12 mm x 12 mm so the maximum length of A is $(3 \times 12) - 1 = 35$ mm.

So, any length between 35 and 37 mm meets the quality standard. If yours is outside these limits, correct it by sanding or remaking.

If dimension B has a tolerance of ± 0.5 mm, what are its maximum and minimum lengths?

Max. = _____

Min. = _____

The tolerances for each of these dimensions is 1 mm

Write down the maximum and minimum dimensions for dimensions D.

Max. = _____

Min. = _____

2. Assemble the Soma Cube completely and stand on a flat surface and measure distances C, D and E using a ruler.

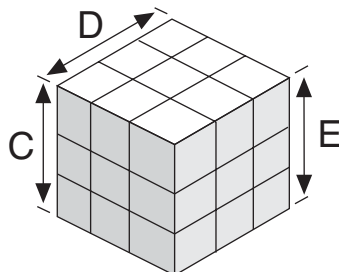

C= _____

D= _____

E= _____

12 mm x 12 mm softwood costs 31 pence per metre. Work out the cost of the softwood you have used.