

TYPES OF MANUFACTURING SYSTEMS

Is all manufacturing the same?

For most people, the word will conjure up pictures of production and assembly lines making very large numbers of products - such as motor cars, televisions, compact discs, clothes and so on. You may wish to ask the following questions:

- * Is the type of manufacturing system used to produce cars the same as the one that makes jeans?
- * Is a ball-point pen made in the same way as the furniture in your home?
- * Are manufacturing systems the same across the world - in different countries and cultures?

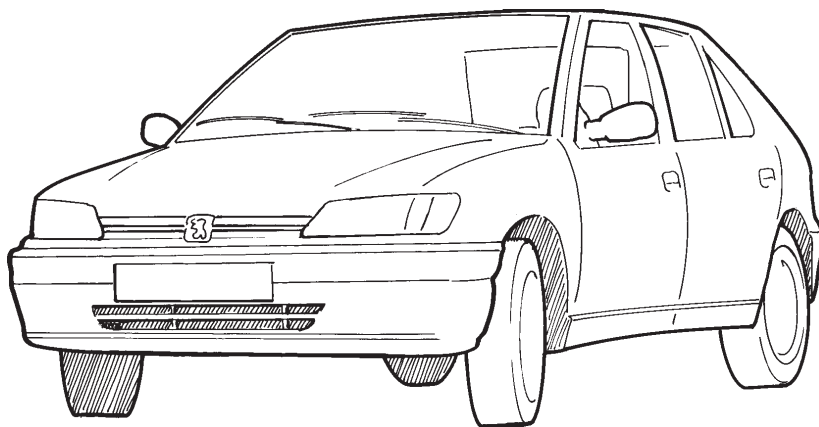

Because of the very broad range of products that are manufactured, several different types of manufacturing system have evolved. Each system meets the unique demands and characteristics of the product and the market in which it will eventually be sold.

There are a number of ways in which manufacturing systems can be classified:

(a) Process or continuous production: this is where the plant or factory may run twenty-four hours a day, for weeks or months on end, stopping only for maintenance or when breakdowns occur. This type of production is normally found in industries such as chemical processing, food production and steel making, and in China for example, with the making of chopsticks. Products that depreciate quickly, or are in high demand are often continuously produced.

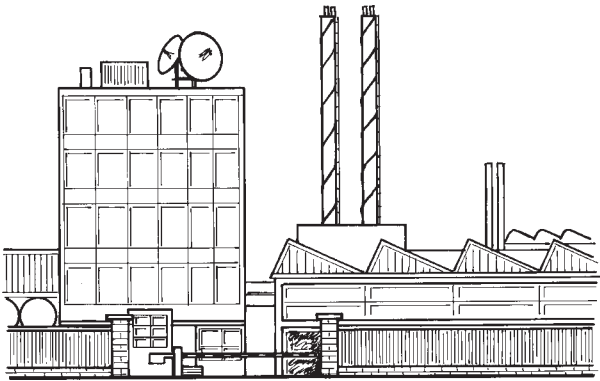

The output from the plant is normally expressed in weight or volume of goods produced, rather than in numbers of products made. The cost of the equipment used in this form of production is likely to be very high, as it is likely that it will have been made specially. Because many of these processes are automated, labour costs are generally low.

b) Mass production: large quantities are again involved in mass production, but in this case it is individual products that are manufactured - for example, motor cars, 'white goods' such as refrigerators and washing machines, personal stereo systems etc.

As with continuous production, highly specialised and therefore expensive machines are used. The variety of the product manufactured is kept to a minimum where possible to minimise any changes necessary to the tooling, which will take time and therefore cost money.

Most of the operations undertaken in mass production are repetitive and can become very tedious for human workers, who may feel they have little decision-making power or control over the outcome of the final product. Bored or disillusioned workers are likely to make mistakes. Many companies have made great investments of time and money to enhance the quality of work life for their operators by using a system of job rotation, and through making teams of workers responsible for the quality of what they produce.

Quality circles are composed of groups of workers who meet on a regular basis to discuss and solve quality problems. They investigate causes of faults, recommend changes, and then take corrective action. In this way, workers are motivated to take pride in their work and become involved in maintaining quality standards. Waste from defectively made products is reduced dramatically, whilst productivity and quality are increased.

Robots are used increasingly for manufacturing and assembly tasks - they produce more consistent quality, are generally faster, do not become tired or ask for holidays!

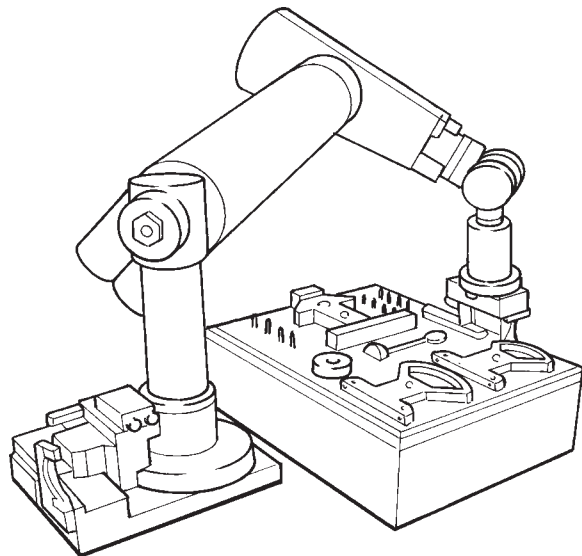

In mass production systems equipment, labour and supply of materials and components are highly organised (increasingly through the use of computers to monitor and control processes) to ensure a smooth flow of work through the factory and thereby minimise the cost of making each product.

(c) Batch production: This type of manufacturing makes products in specific quantities. These made be made in one production run, or in batches to be repeated at certain times. A batch can range from 2 or 3 products to a hundred thousand or more. Aircraft are produced using small batch production - agricultural machinery, furniture, machine tools, buses and lorries (other examples needed here) are made in larger numbers.

In a batch production manufacturing system, each piece of equipment may be used to make several different products. This means that the machinery used must be far more versatile than that used in mass production. The workers who operate them are likely to be more skilled.

In a large factory, many batches of different products of varying quantities, scheduled for different customers and delivery dates, will be processed at any one time. This can pose some serious problems of planning involving the use of machines and the personnel to operate them if orders are to be met on time. The use of computer-controlled machines and computerised production control and management systems are increasingly used in an attempt to bring down the costs of production.

In an attempt to increase versatility and flexibility in batch production processes, manufacturing cells are increasingly used. *Manufacturing cells* are normally groups of machines, normally involving sheet-metal forming or machining operations, with each piece of equipment performing a different operation on a component. The machines can be retooled and regrouped for different product lines within the same family of parts. The cells are typically attended by one operator overseeing the group of machines, although increasingly they are becoming computer-controlled, employing robots for materials handling.

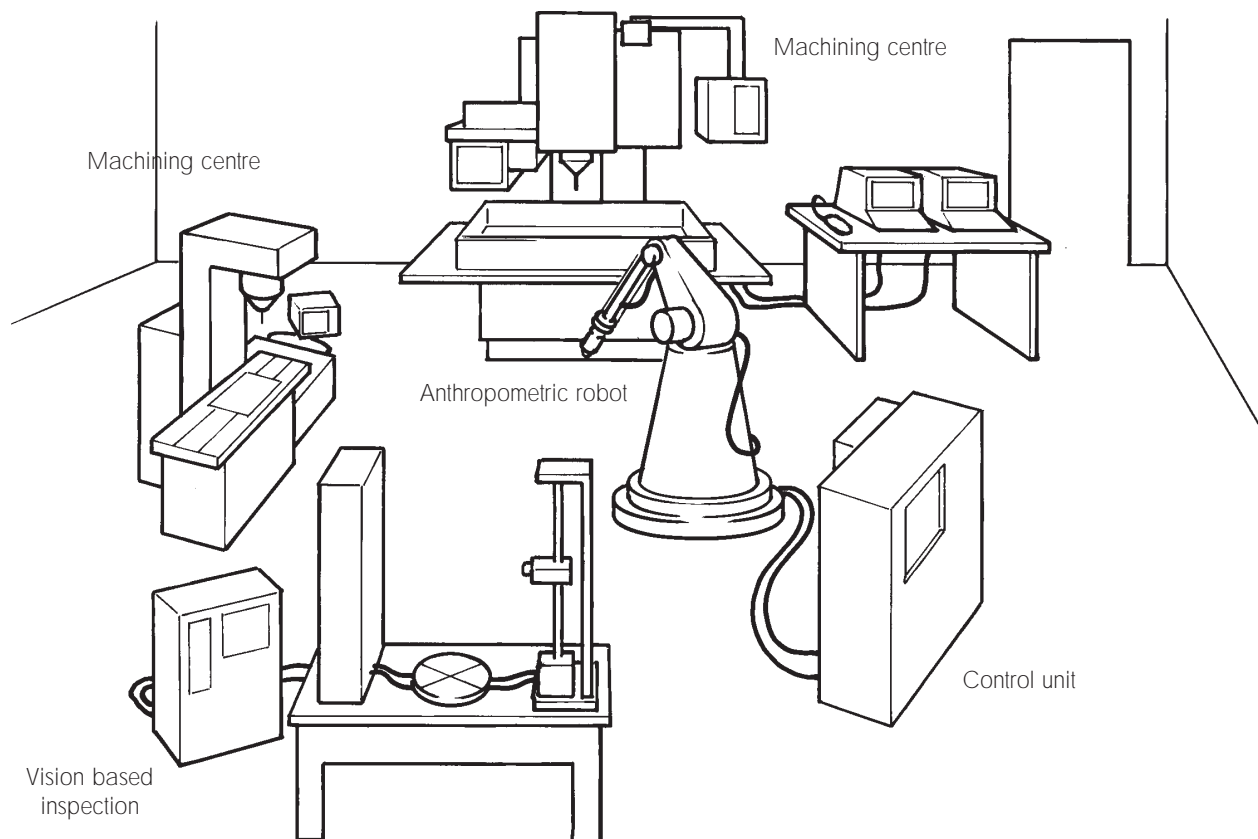

Systems that are able to respond quickly and effectively to changes in product manufacture are known as *flexible manufacturing systems*. FMS integrates all the major elements of manufacturing into a highly automated system. It normally consists of a number of manufacturing cells, each containing an industrial robot serving several CNC machines, and an automated materials handling system - all linked to a central computer. FMS systems are highly automated and are capable of optimising each step of the total manufacturing operation. These steps may include one or more operations or processes, such as machining, grinding, cutting, forming, heat treatment and finishing, as well as handling raw materials, inspection and assembly. These automated systems of batch production are able to operate on a continuous basis.

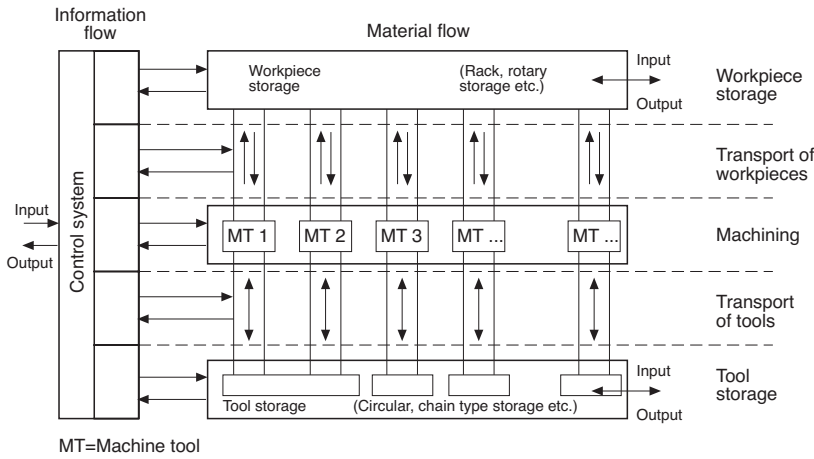

(d) Jobbing production: also known as *custom manufacturing*. This system of manufacturing produces normally one product at a time, normally to a single customer's specification. Highly skilled workers and general purpose equipment are used. Problem-solving and trouble-shooting are necessary because each product presents new challenges. Products that are custom-manufactured are normally very expensive, and might include large yachts, space satellites, oil rigs and special purpose machine tools.

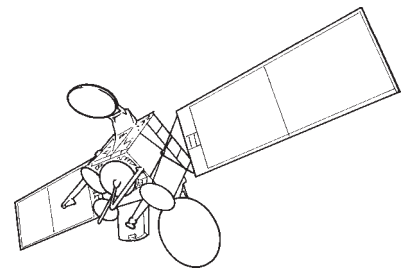

Many traditional craft products, such as jewellery and pottery are often made using custom manufacturing techniques.

Just-in-Time (JIT)

manufacturing is a system that can be applied to continuous, mass, batch and jobbing production. JIT was developed in Japan to eliminate the waste of materials, machines, labour, money and stocks held (known as 'inventory') throughout the manufacturing system. The JIT idea has the following goals:

- purchase supplies of materials and components from outside suppliers just in time to be used
- produce parts just in time to be made into subassemblies
- produce subassemblies just in time to be assembled into finished products.
- produce and deliver finished products just in time to be sold.

Using JIT principles means that the sizes (or 'lots') of materials and components purchased or manufactured are likely to be smaller. It is therefore easier to spot any defects or faults. The advantages of using JIT are:

- low costs associated with inventory (stocks held on shelves)
- fast detection of defects in production or in delivery of supplies, and lower scrap loss
- reduced need to inspect parts to ensure they meet specification
- less reworking of parts
- high quality parts at low cost.

COMPUTER -INTEGRATED MANUFACTURE

Computers are now used in many ways in the design and manufacture of products. With sophisticated hardware and software, manufacturers are now able to:

- improve product quality
- minimise manufacturing costs
- reduce product development time
- make better use of materials, people and machinery
- maintain a competitive edge in the domestic and international marketplace

Where the traditionally separate functions of research and development, design, production, assembly, inspection and quality control are all linked through the use of information technology, this is known as computer integrated manufacturing. It is not just the use of computers that is important - it is the way that a company's operations are *planned* and *integrated* that brings success.

Elements of a computer integrated systems include:

- *computer-aided design and draughting (CADD)* - allows for the conceptualisation of new products more easily
- *computer-aided manufacture (CAM)* - involves monitoring and controlling the manufacturing operations
- *computer-aided process planning - (CAPP)* such as estimating costs or the time taken to perform a certain manufacturing operation
- management information systems for marketing, finance, payroll etc.

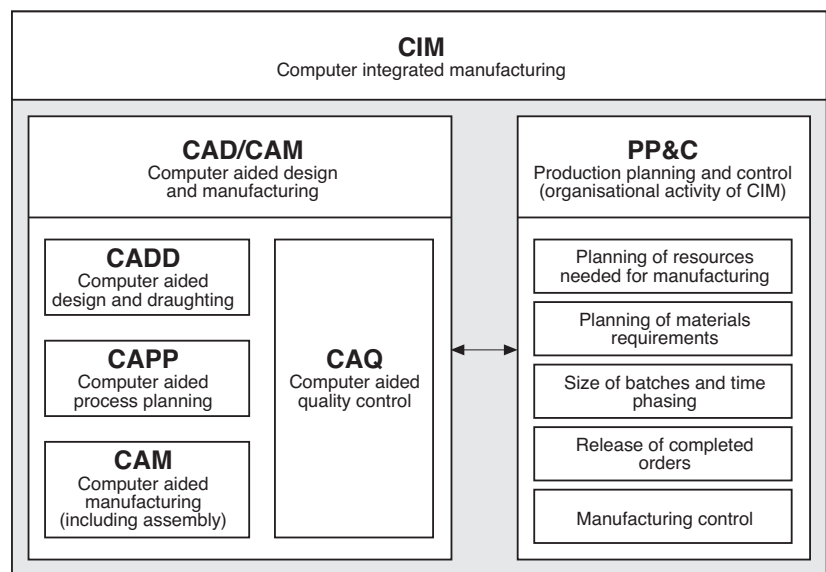

CHOOSING AN APPROPRIATE TYPE OF MANUFACTURING SYSTEM

Choosing the most appropriate type of manufacturing system for a particular product will depend upon the following factors:

- the volume (quantity) to be produced
- availability of necessary equipment and machinery, or appropriately skilled workers
- the type of product to be made
- the life cycle or durability of a product
- the production philosophy of the organisation