

DESIGNING AND MAKING A PANTOGRAPH ENGRAVER

WHAT YOU WILL LEARN

After completing this unit, you should understand:

- How linkages change input movements.
- The reduction and enlargement principle of a pantograph.
- Why a pantograph linkage is used for engraving.
- How to model linkage systems.
- The importance of avoiding 'play' in linkages.

After completing this unit, you should be able to:

- Work to a design brief and write a specification.
- Recognise constraints when designing.
- Design and make some parts for a pantograph.
- Assemble and adjust a pantograph linkage system.

MECHANISMS - PANTOGRAPH ENGRAVER

If you have something which is engraved with your name such as jewellery or a trophy, the lettering was probably done with a machine called a pantograph engraver. These machines are used by jewellers and firms that make nameplates. They are also used in the early stages of making our metal coins.

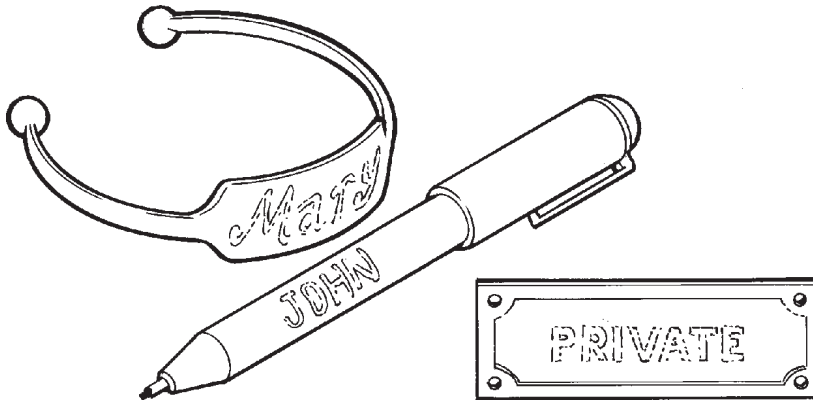

The main part of the engraving machine is a pantograph mechanism. It consists of four connected parts that allows shapes to be copied and enlarged or reduced. A pantograph is very easy to make and can be turned into an engraving machine by adding a small electric motor with a cutting head. A cutting head is a motor turning a cutter at high speed.

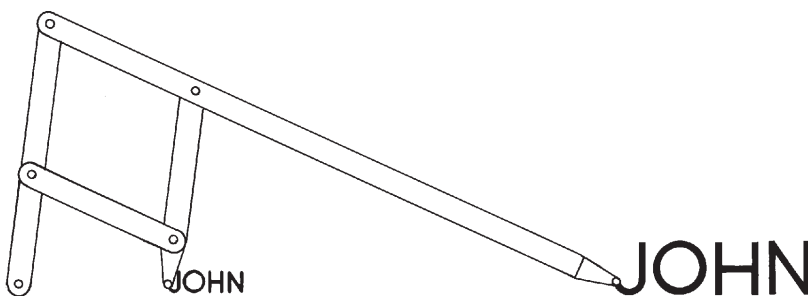

◀ NOTE
See Study File 7 (Four Bar Linkage)

This unit invites you to design and make an engraving machine which you can use to engrave lettering and pictures onto metal and plastics.

MECHANISMS - PANTOGRAPH ENGRAVER

THE PANTOGRAPH

The pantograph mechanism is an example of a linkage system. Linkages consist of connected parts with an input and an output. A linkage can change the direction, speed or size of the input movement.

- Changing direction of movement.

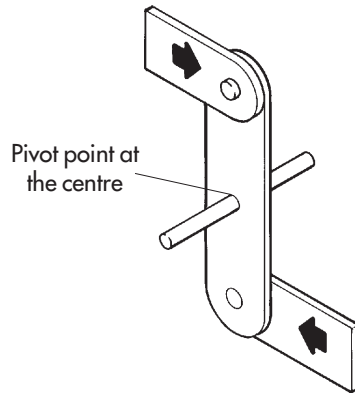

- Changing direction, size and speed of movement.

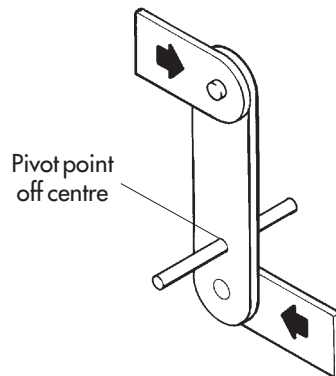

Linkages are used within large and small machines to get movements from one place to another. When you push the 'eject' button on portable cassette players, a linkage connects the button to the opening lid.

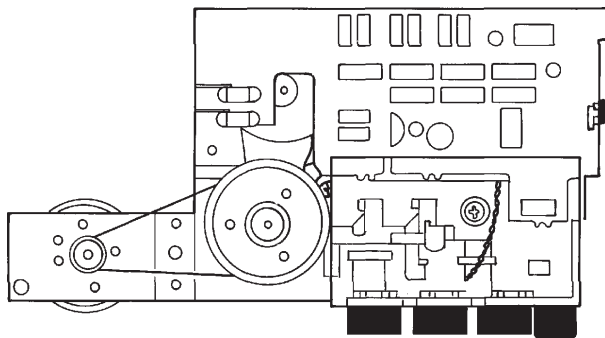

Personal stereos often use a range of mechanisms such as pulleys and levers

MECHANISMS - PANTOGRAPH ENGRAVER

Linkages can also change the type of movement. A windscreen wiper mechanism is an example of a four-bar linkage - so called because it has four parts or bars.

- Changing type of movement from rotary to arcing to and fro.

◀ NOTE

See StudyFile5 (Analysing Mechanisms)

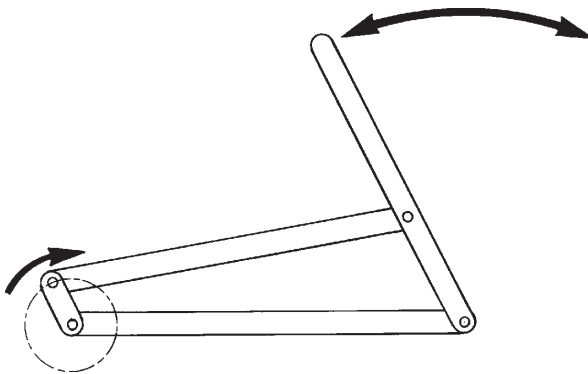

The pantograph is also an example of a four-bar linkage. Any kind of input movement to a pantograph produces an identical output movement but changes its size. Because of this property, pantographs were used widely for making enlargements or reductions of pictures before photocopiers and computers were available.

A simple pantograph mechanism is shown below. When the end of the bar (point A) is moved around the outline of a picture, a pencil at point B makes exactly the same movements - but smaller. (Similarly, if point B is moved around a picture, a pencil at point A would make exactly the same movements - but larger.) The pantograph input (point A) is also called the follower.

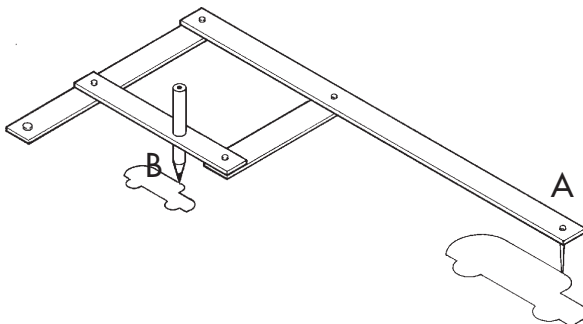

MECHANISMS - PANTOGRAPH ENGRAVER

In simple pantographs for drawing, the bars can be made of wood, metal or plastic. The bars are normally held together with metal rivets acting as pivots and there is a pencil or pen holder at point B.

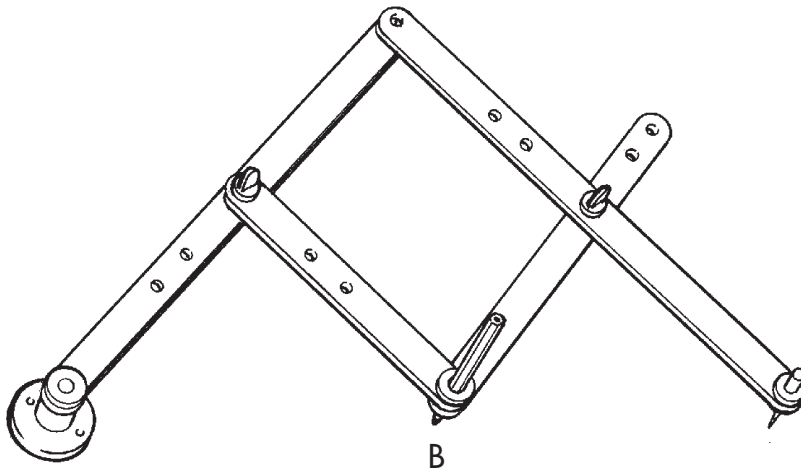

An engraving machine which uses the pantograph principle has four very stiff bars (that cannot flex or bend) and very accurate pivot joints. Instead of using a pencil to make marks on paper, the engraving machine uses a high speed cutter to create a groove.

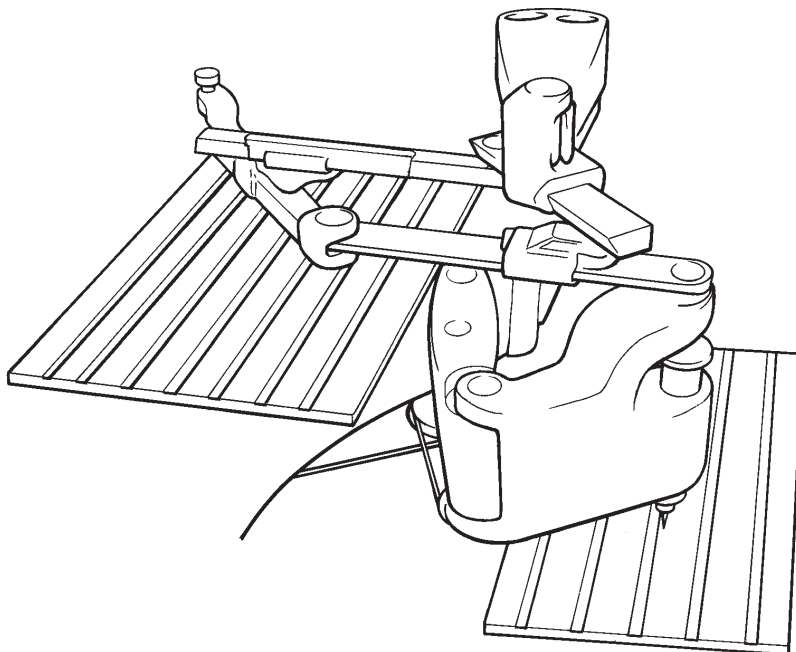

INVESTIGATING THE PANTOGRAPH

The most effective way to understand the pantograph principle is to make a model of one using card strips. These can be joined either with eyelets, using a special punch tool, or with paper fasteners. Holes for the paper fasteners can be made with a hole punch or a bradawl.

◀ MATHS/SCIENCE OPPORTUNITY

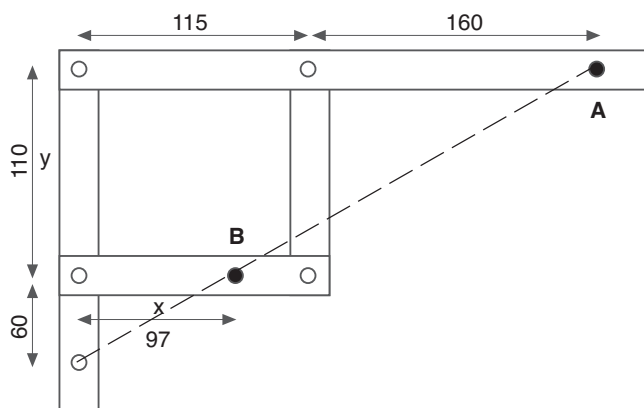
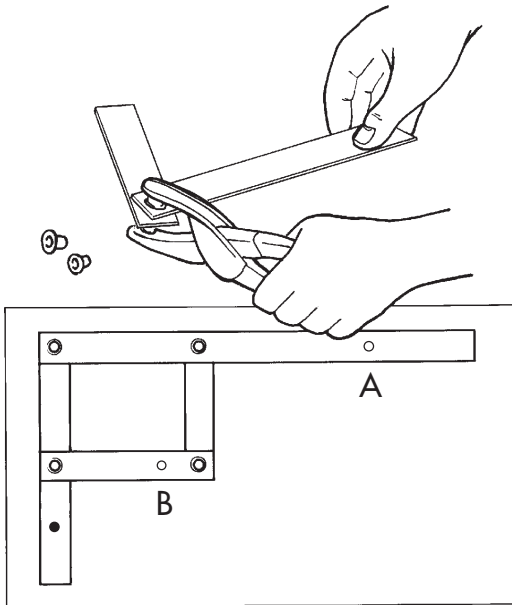

Typical measurements shown in mm

The overall dimensions suggested for your model will give you a size reduction of about one third from point A to point B. This is normally expressed as a ratio. Instead of saying 'one third', we say a 3:1 reduction. If the original being copied is 3 cm high, the output of the pantograph will be 1 cm high.

MECHANISMS - PANTOGRAPH ENGRAVER

Draw a square 30 cm x 30 cm to move the follower of your model around. As you move the follower, lightly press a sharp pencil through a small hole close to the pivot point B.

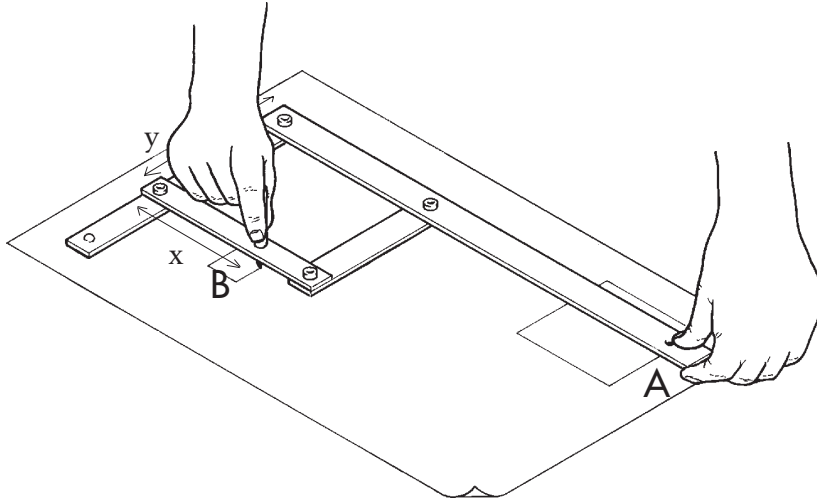

The amount of reduction between point A (input) and point B (output) is determined by the two distances 'X' and 'Y'. If you move the fixed pivot point towards the top of the pantograph and the pencil to the left, the output gets smaller. However, the fixed pivot and the pencil need to be moved the correct distances otherwise the output is distorted.

Use your model to answer the following questions:

- What distances for X and Y would give a reduction of 2:1?
- Can you draw scales on the two bars to allow you to see quickly the positions for the fixed pivot and the pencil?

This kind of modelling can also be done on a computer.

◀ NOTE

After a pantograph is adjusted, it is essential that the fixed pivot, output (pencil) and input (follower) line up as shown by the dotted line. Ideally the output point (B) should coincide with the centre pivot. In practice, it is more convenient to mount the motor to one side and accept a slight amount of distortion in the copy image.

MECHANISMS - PANTOGRAPH ENGRAVER

You will see from your investigation that the reduction ratio of the pantograph can easily be altered. You will also see that the reduced image can be distorted by altering only one distance - or both in the wrong proportions. This could be a useful feature on the engraving machine if you wish to alter the appearance of lettering or a picture!

YOUR TASK

Design and make a pantograph engraving machine for engraving letters or pictures onto the surface of aluminium sheet. To prove that the engraver works effectively, engrave your name onto a small tag for key ring identification.

DESCRIBING YOUR TASK

First, you need to draw up a specification for your engraving machine. A specification is a more detailed description of what a product will be like, what it will do and who will use it.

Here are some questions to help you produce the engraver specification:

- What will you use as lettering for the follower to trace over?
- What is the maximum size of the pantograph?
- Is the pantograph to be transported?
- Will the pantograph be adjustable to give different size reductions?

WHAT YOU HAVE TO WORK WITH

Before you start your design work, you need to know what materials and equipment are available. Your teacher will provide you with some of the items listed below. Make a note of what is available.

- Electric motor (with spindle ground by your teacher as a cutter)

- Rectangular section plastic tubing (19.1 mm × 9.5 mm)

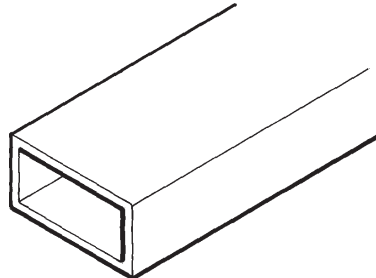
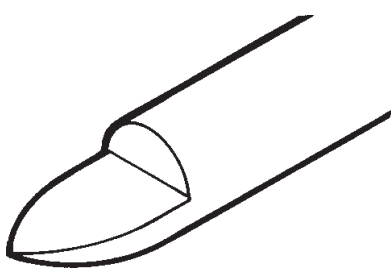

◀ DESIGN BRIEF

◀ DESIGN SPECIFICATION

◀ DESIGN CONSTRAINTS

◀ NOTE

Pantograph components are available as a pack. Solid as well as hollow sections can be used for the bars if there is adequate stiffness.

MECHANISMS - PANTOGRAPH ENGRAVER

- Plastic tubing 9 mm diameter)

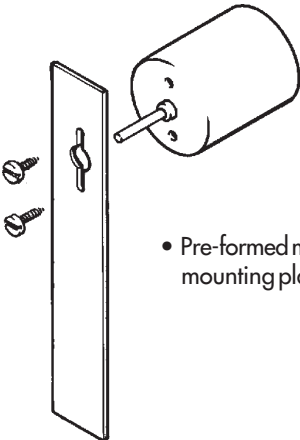

• Pre-formed motor mounting plate

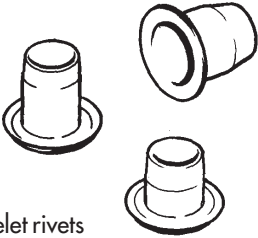

• Eyelet rivets

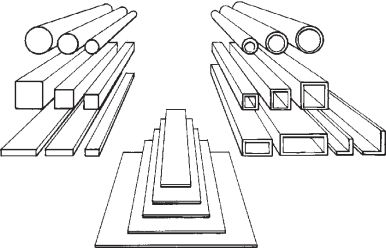

• Selection of sheet, rod and sections.

• Card strips

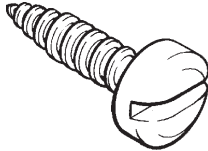

• Self-tapping screws

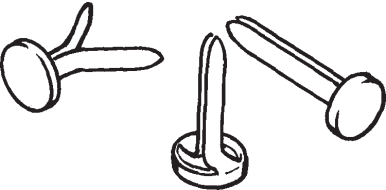

• Paper fasteners

• Graph paper

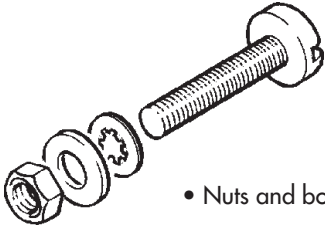

• Nuts and bolts

• Plastic or metal sheet

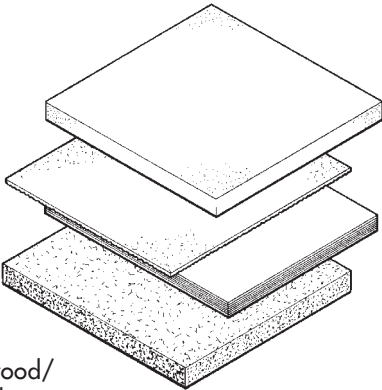

• MDF/plywood/
chipboard sheet

MECHANISMS - PANTOGRAPH ENGRAVER

WORKING OUT YOUR DESIGN

Now you know what materials are available to make the pantograph, you need to think in more detail about the design:

- Set your ideas down on paper.
- Play around with your ideas.
- Check your ideas against your specification
- Decide which is the best design.
- Do a detailed drawing of the design.

You need to end up with a working drawing from which you or someone else can work to mark out, make and assemble the parts. It will be a good idea to draw the parts for your design full size.

◀ DESIGN PROPOSALS

◀ NOTE

See TechnologyStudyFile2(Communication)

GUIDELINES ON DESIGNING AND MAKING

The following notes give you more information on pantograph linkages. They also give you some ideas about designing the engraver and methods of making it. They do not give you the answer though! You must make the important decisions and assemble the parts so you end up with a working product.

MAKING A PANTOGRAPH ENGRAVER

Base board

The engraving machine needs a rigid base. It must hold the workpiece securely and provide a place for the lettering etc. that you will copy from. The fixed pivot will also be secured to it.

The size of your base board is determined by the overall size of the pantograph you design but it does not need to be the whole size of the pantograph linkage.

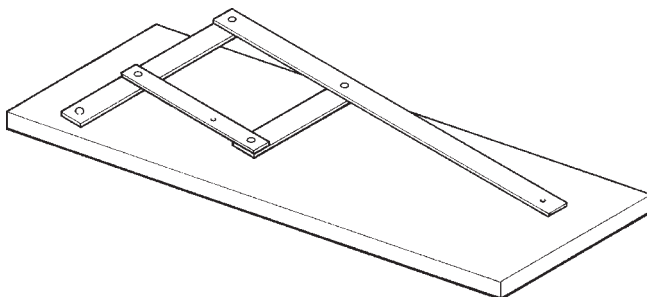

Holding the workpiece

The piece of metal to be engraved must be held very tightly. Taping it down is not really secure enough; a better alternative, for example, is to make small clamping pieces that screw down onto the board. (The lettering or image to be copied can be taped down at the corners by masking tape.)

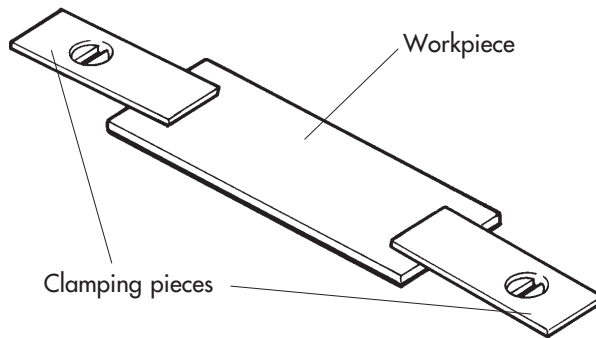

Pantograph bars

Your card model will have shown you that the bars of the pantograph linkage need to be as stiff as possible and the pivot joints need to be free to move but not 'sloppy'. In a pantograph engraver, it is very important that the bars are stiff and there is no 'play' in the joints. 'Play' means looseness.

You should not attempt to make the bars from thin metal or plastic strips. An ideal material is rectangular section tubing which is both light and stiff. The recommended size is 19.1 mm × 9.5 mm.

Pivot joints

The joints for your pantograph can be made in several ways. These include the following:

- Spring pins.

A spring pin is a small length of slit tube whose diameter reduces when it is squeezed. These fasteners are normally used for fixed rather than moving joints.

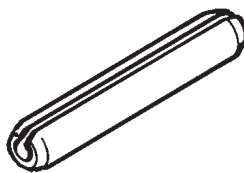

◀ NOTE

It is essential that there is no significant 'play' in the links. At the same time there should be no undue stiffness. The 'all plastic' split pin method is a proven technique.

MECHANISMS - PANTOGRAPH ENGRAVER

Plastic spring pins, however, make good pivots for the pantograph providing they are not too tight. Suitable spring pins can be made by first cutting off lengths of plastic tubing which should, if possible, be faced off on a lathe.

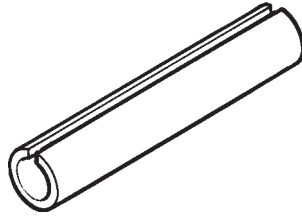

Each pin is then placed lengthwise in a vice and split down its length with a hacksaw.

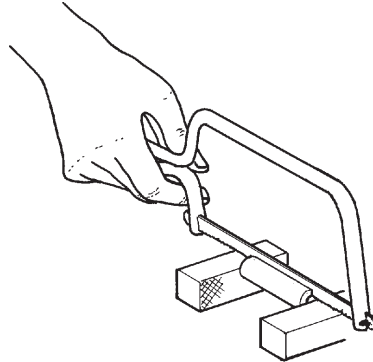

The holes in the pantograph arms into which the spring pins fit should be slightly less than the diameter of the pins. (For a 10 mm diameter pin, drill a 9.5 mm hole.) When the pin is forced in, it closes up slightly and stays in position.

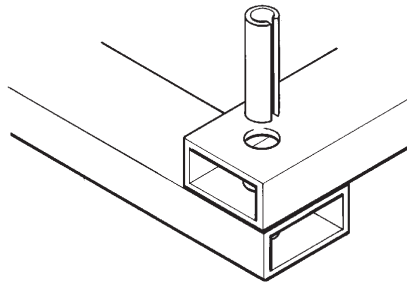

Advantage: provides a pivot without any 'play'.

Disadvantage: May make the pantograph slightly stiff.

• Screw and nuts

If two nuts are placed on a screw and tightened against one another ('locknut'), this provides a pivot joint which can be adjusted for tightness. If this method is to work, the holes drilled into the bars to take the screws must be exactly the same size as the screws.

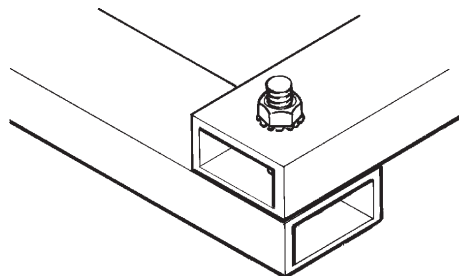

Advantage: a very easy joint to make.

Disadvantage: one or more joints may have 'play' in them.

Mounting the engraving head

The engraving head you will be using is a small electric motor whose hard steel spindle has been ground to create a cutter. The easiest way of mounting this securely to the pantograph bar is to use a pre-formed motor mounting plate which can be cut to length. The motor mount can then be fixed to the smaller pantograph bar as shown. It is acceptable to mount the motor slightly to one side of the bar.

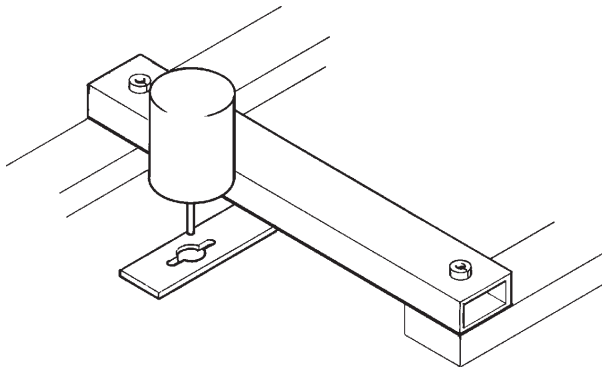

You must ensure that, when the motor is mounted on the arm, the end of its spindle is just in contact with the board. You can achieve this with an MM28 motor if you use 9.5 mm thick rectangular section tubing for the bars. If you use a material of another thickness, the motor mount will need to be adjusted up or down using washers or bending the mounting plate.

◀ QUALITY CHECK

Is the joint without 'play'? How is this measured?

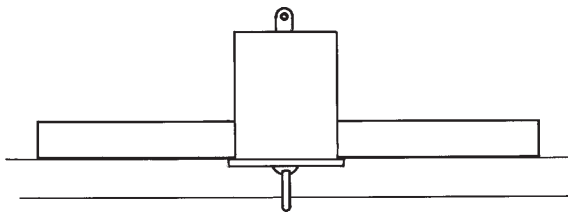

◀ QUALITY CHECK

It is essential that the motor is correctly 'depthed'.

The motor is raised slightly when a piece of metal is placed under the motor spindle for engraving. The weight of the motor is enough to ensure that its spindle cuts into the workpiece.

MECHANISMS - PANTOGRAPH ENGRAVER

It is important that all the bars remain parallel to the surface of the base board. In the illustration shown two, of the bars rest on the board but the input or 'follower' bar has no support at the end. This can be corrected, for example, by adding a 'foot' cut from a section of the material used to make the bars.

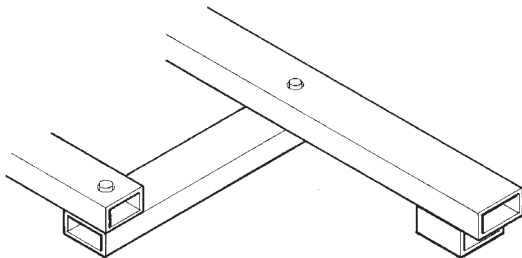

The follower end of the input bar is used to follow the outlines of letters etc. very closely. A small pointer can be added to the supporting foot to make this easier. You could even think about making a clear plastic 'sight' piece with a cross marked on it. How would this be fixed to the bar?

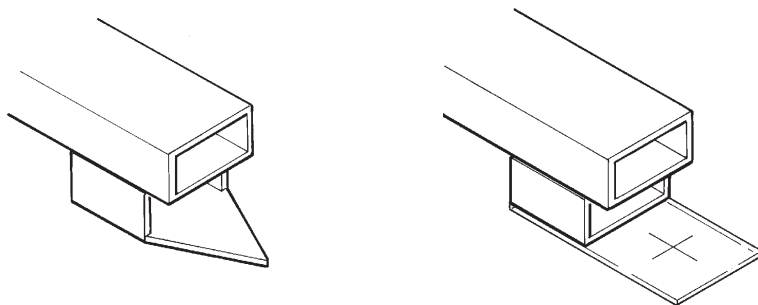

PUTTING IT ALL TOGETHER

If all the parts have been marked out and cut out accurately, it should be easy to assemble your pantograph engraving machine. If you have used nuts and screws to fasten the bars together, they should be adjusted so the bars can move but are not loose.

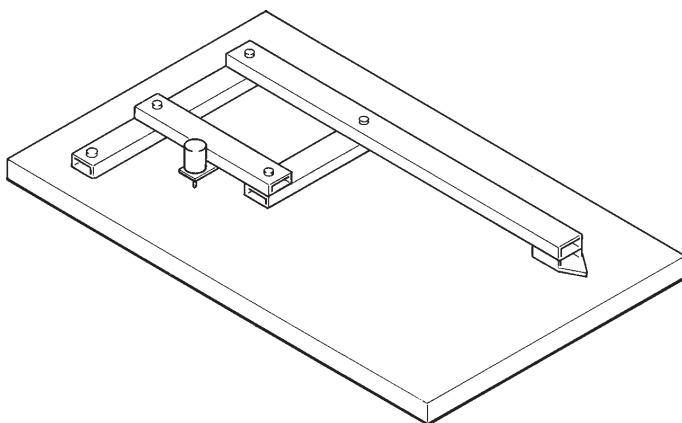

← QUALITY CHECK

It is essential that the bars are parallel to the base and that the tip of the motor spindle just touches the surface of the workpiece.

MECHANISMS - PANTOGRAPH ENGRAVER

OPERATING YOUR ENGRAVING MACHINE

When you set up the engraving machine, make sure that the fixed pivot, the cutting head and the follower point are in a straight line.

Ideally, when you start engraving, the motor should be running and held up slightly off the work. Lower it as soon as you wish to engrave. To engrave separate letters, either lift the motor slightly at the end of each letter or switch it off. You will find it much easier to engrave joined up lettering.

EVALUATING YOUR ENGRAVING MACHINE

To evaluate the success of your engraving machine, you must ask whether it meets your specification. You will need to carry out some tests to find out if:

- You can engrave on aluminium when the engraver is set up and turned on. If the motor spindle 'wanders' on the surface when engraving, check whether one or more of the pivot joints are loose. Also, make sure the motor is tightly fastened to the pantograph bar.
- The motor spindle cutter cuts a neat groove. If it doesn't, the motor spindle may need re-grinding.
- You can lift the running motor off the workpiece while you are moving the follower to another place. If this is awkward, you may need to think about adding to your basic design .
- The workpiece moves during engraving. If it does, you might need to think about a design modification.
- The engraved copy is distorted in outline. If it is, you will need to adjust the 'X' and 'Y' distances.

◀ MATHS OPPORTUNITY

Deliberate adjustment of geometry will produce interesting copy distortions.

MECHANISMS - PANTOGRAPH ENGRAVER