

Part 2 TEP

PrESS Teacher Guidance UNIT

PrESS is the acronym for Practical Electronics Support for Schools

In this second installment of the PrESS mini series we take a closer look at the FET or field effect transistor.

This mini series will cover worked examples and applications for: Thyristor, FET, PIC's, IQ2, 555 Timer, Infra Red, Op Amps

FET

How it works

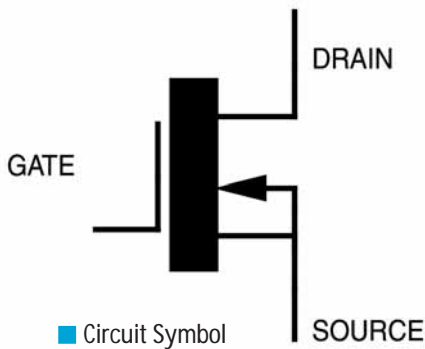

The field effect transistor is a voltage controlled semi-conducting device; the input voltage controls the output current. There are two main types of field effect transistor; the metal oxide semiconductor field effect transistor (MOSFET) and the junction field effect transistor (JFET). MOSFETs give high power, high speed switching for power supplies, motor speed controllers and audio amplifiers. FETs have three terminals called source, gate and drain. Conventional transistors rely on a base current and gain characteristics.

A typical wired configuration is in series with the output or load as shown here

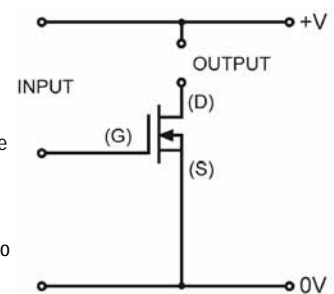

They are capable of amplifying very low current signals as they have this high input impedance and because they are more essentially voltage dependent. They are useful in radio and audio electronics. Systems electronics often uses FETs as part of a transducer driver subsystem and are a good choice of device in switched digital projects and applications.

FETs do not work like that.

FETs can be used to supply large currents or switch high current devices on or off. FETs have a very high input impedance or resistance which means they draw very small input current and they are voltage controlled (2V) and not dependent on a 'base current'. They are really easy to use, fairly robust and feature a metal back for attaching to a 'heat-sink' as they get warm handling larger currents.

The FET is also variously described as a smart transistor. The FET (field effect transistor) functions as an electronic switch capable of passing very high currents. Some FETs are smarter than others because they contain circuitry capable of sensing conditions such as temperature and can protect themselves.

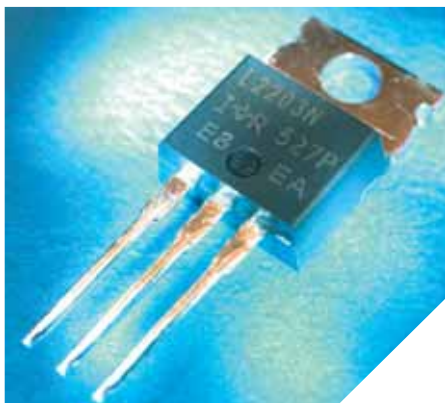

■ Component

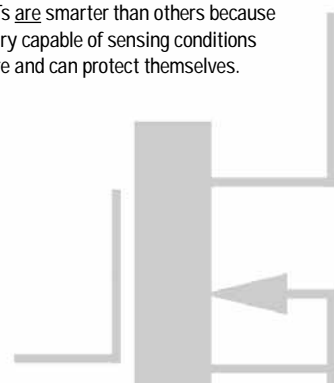
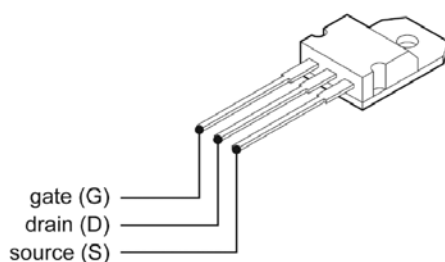

Controlling FETs

Used as a switch, the FET is connected into the circuit shown. No current passes between *drain* and *source* unless the FET's third leg, the *gate*, 'sees' a positive voltage. To turn the FET 'on' a connection is made between the *gate* and +ve – e.g. by bridging with a length of wire or just using damp fingers. The important point to note is that the FET can pass a very high current *drain* to *source*, but only requires a voltage level at the gate to turn it on and off. Because the *gate* input is so 'sensitive', the FET can turn on unexpectedly if there is a tiny amount of moisture on the board.

Because the *gate* input is so 'sensitive' and only needs very low currents to turn it on it is really important to steer the input with a suitable potential divider or it can turn on spuriously.

One way of overcoming this problem is to connect a high value resistor (anything from 1M to 10M) between the *gate* and –ve. This prevents the *gate* 'floating' and turning the FET on when not required. FETs are used widely as switches in places where previously a relay would have been employed.

FETs can in many cases replace expensive and unreliable relays because they can handle large currents directly. They can be used to turn on and off quite substantial loads to motors and other high current devices yet are a simple buffer for complex and sensitive digital or PIC based circuits.

In some ways the FETs most useful characteristic is that it can as a single component replace more complex circuits as a decision block in a process.

Applications and contexts

Touch Sensor. To create sensitive circuits to detect conductivity as a 'touch switch' or moisture sensor the potential divider input is wired as shown. The 1M resistor 'steers' the input so that a lower resistance on the input leads creates a higher voltage in. Replacing the fixed resistor with a variable one allows the user to alter the sensitivity.

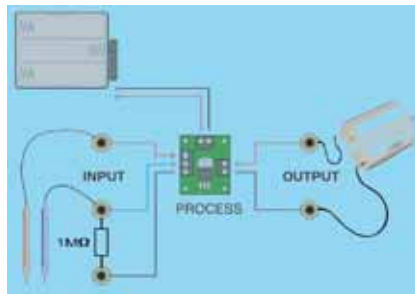

Light sensor. The gate of the FET is connected at the junction of an LDR (light dependent resistor) and variable resistor. These two components form a potential divider whose voltage at the centre varies according to light level. In subdued light, the voltage at the centre is insufficient to turn on the FET.

As the light level increases, the voltage also increases and eventually reaches the turn-on threshold. The reverse happens if the positions of LDR and resistor are reversed. (After experiment, a fixed resistor might be substituted for the variable type.)

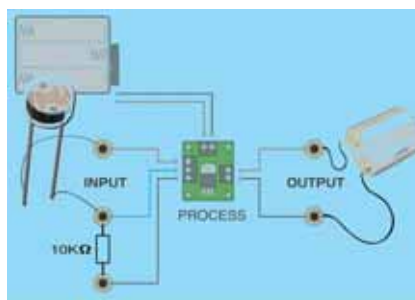

Contexts

Controlling the input voltage to the gate with a resistor / capacitor circuit as a CR or RC circuit that can provide useful time delays to switch on or switch off a FET (you can follow up this method in the next issue with a useful 'maths free' ready reckoner table). These FET sensor circuits can be used in contexts such as alarms, environmental controlled switching and feedback control in systems. A number of high current outputs for large motors can be connected – e.g., a combined motor/pump system. For PIC driven projects the FET can be wired typically as shown in the diagram >

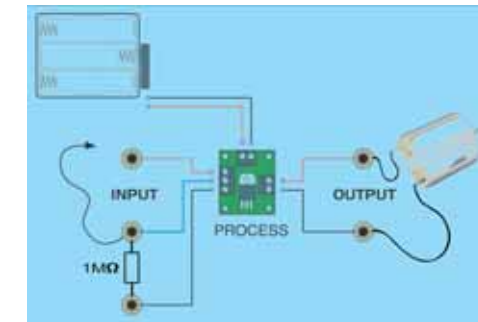
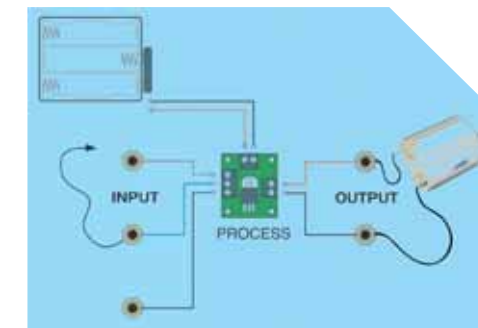

Technical Notes

- Switch large currents in series eg: 14Amps
- FET's are voltage controlled (2V) not dependent on a 'base current' and have a high input impedance
- A typical FET is an IRF530
- Housed in a TO 220 Case
- They are better as a digital switch than a bipolar transistor
- FET's are sensitive to static electricity
- A heat sink is needed when switching over 2 Amps
- Can pulse up to 56Amps!

Really low-cost projects under £1.00 excluding batteries are possible. A FET teaching and learning board is also available. Due to the simplicity of the circuit it is a great 'fault free' introduction for pupils and students and can be on PCB, copper tape or breadboard too.



A Press teaching aid and PCB are available separately from MUTR Code: ELE 028A

Readers can download a FET animation and the previous one on thyristors from the TEP website under the Electronics and What's New tab along with teachers' notes and animations and a comprehensive PDF covering the applications and key points.

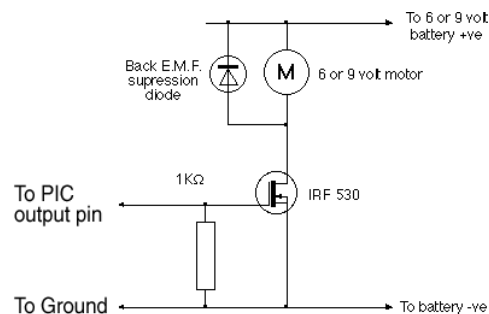
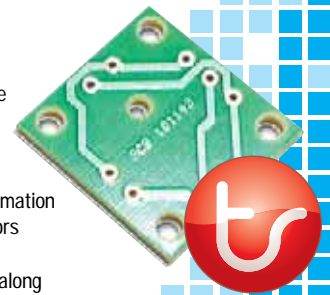

■ **Next Issue:** we will look at the useful and often overlooked monolithic Timer