

AN INTRODUCTION TO POLYMERS

INTRODUCTION

It is very difficult to realise how important plastics have become to our everyday lives. We always seem to have known these materials, and we tend to take it for granted that they occur every day and all around us, for example in our clothing, the pen that we write with, the chair that we sit on or wrapping the food that we eat. Look around you; how much plastic do you see?

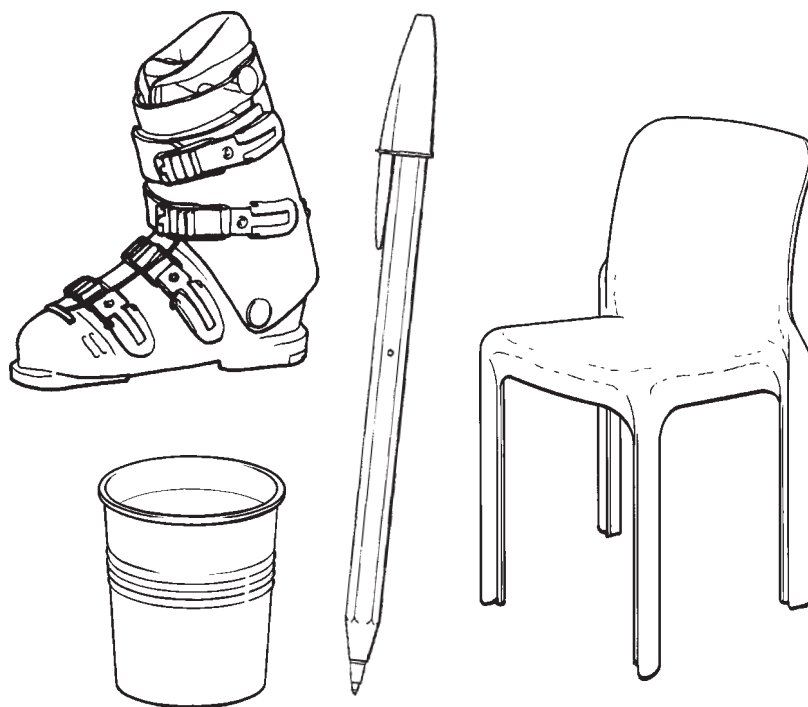

So it is sometimes hard to believe that plastics have only been commonly available for about the last one hundred years. Yet in this time the impact that they have made upon the quality of our lives and on the products that we have access to, has been enormous.

Plastics give us the possibility of manufacturing well designed and beautiful products from the very many different types of plastics that are commonly available today. Within manufacturing technology there is a very high degree of technological understanding of plastics and a range of sophisticated technological processes that enable us to make them and shape them in numerous ways. This book aims to show you a little of what can be done.

THE TERMINOLOGY OF PLASTICS

If you are going to really understand plastics you are going to have to learn a lot of new terms. Some of these terms are not particularly easy to pronounce but you will learn with practice. Try saying 'oxybenzylmethyleneglycolanhydride'. Perhaps it is easier to call this plastic by its other name, which is Bakelite! Where possible you must try to learn the correct terminology when talking about plastics.

The word plastic itself comes from the Greek word *plastikos*, which means to be able to be shaped or moulded by heat. As we will see, shaping plastics by using heat is a basic part of nearly all plastics manufacturing processes. Like timbers, which can be divided into hardwoods and softwoods, and metals which can be divided into ferrous and nonferrous metals, plastics can also be divided into categories:

- **Natural plastics** - these are naturally occurring materials that can be said to be plastics because they can be shaped and moulded by heat. An example of this is amber, which is a form of fossilised pine tree resin and is often used in jewellery manufacture.
- **Semi synthetic plastics** - these are made from naturally occurring materials that have been modified or changed by mixing other materials with them. An example of this is cellulose acetate which is a reaction of cellulose fibre and acetic acid and is used to make cinema film.
- **Synthetic plastics** - these are materials which are derived from breaking down, or 'cracking', carbon based materials, usually crude oil, coal or gas, so that their molecular structure changes. This is generally done in petrochemical refineries under heat and pressure, and is the first of the manufacturing processes that is required to produce most of our present day, commonly occurring plastics.

Synthetic and semi synthetic plastics can be further divided into two other categories. These two categories are defined by the ways in which different plastics react when heated.

1. **Thermoplastics** - these are plastics which can be softened and formed using heat and when cool will take up the shape that they have been formed into. But if heat is reapplied they will soften again. Examples of thermoplastics are acrylic and styrene, probably the most common plastics found in school workshops.
2. **Thermosetting plastics** - these are plastics that soften when heated and can be moulded when soft and when cool they will set into the moulded shape. But if heat is reapplied they will not soften again; they are permanently in the shape that they have been moulded into. Why this happens we will look at later. Examples of thermosetting plastics are polyester resins used in glass reinforced plastics work, and melamine formaldehyde used in the manufacture of Formica.

AN INTRODUCTION TO POLYMERS

'Polymers' is a general term for all plastic materials and means that they are organic, carbon based compounds whose molecules are linked together in long chain patterns. Later on in this book we will look more closely at the molecular structure of plastics so that we can understand how we can make this work to our advantage when designing and making things. When we talk about plastics in general we will call them polymers, and when we talk about specific plastic materials we will give them their real names, such as nylon or polythene.

THE EARLY HISTORY OF POLYMERS

The three part classification of polymers that we have just looked at gives us an insight into the history of their use. Naturally occurring plastic materials can be found in the forms of animal bones, horns, tortoise shells, the fossilised resin from pine trees (amber), the albumen in egg, the sap from various tropical trees, and the wax from bees, and many of these natural polymers are still in use today. Casein, derived from milk, is still used to manufacture buttons. Bitumen is still used in housing and roads; shellac, which was used for early gramophone records, is still used in the production of wood varnish. Shellac, which is produced by the lac beetle, was used by early Chinese cultures as a varnish and as such is still in use. In the nineteenth century it was mixed with fillers and moulded into brush backs, mirrors and picture frames.

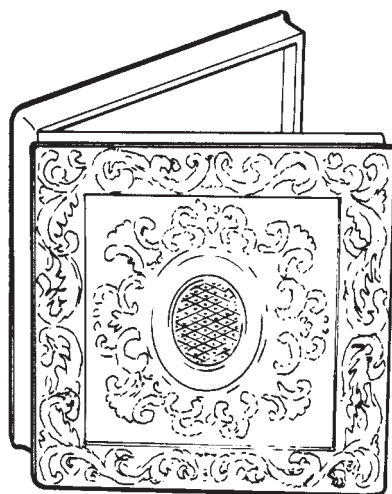

Moulded shellac picture case

Papier mache, which because of its mouldable properties can be considered a plastic was patented in 1772. Gutta percha which, like latex, is extracted from tropical trees was used to make a wide range of household items and also to insulate the first submarine telegraph cable between Dover and Calais. It is still used in the manufacture of some types of golf balls.

AN INTRODUCTION TO POLYMERS

In 1838 Charles Goodyear heated latex rubber with sulphur to make a durable and elastic material. He found that the more sulphur that he added the harder the material became and he termed his new invention 'vulcanite'. This was the first time that a natural polymer had been deliberately modified and so was the first of the semi synthetic materials. One of the uses that was found for it was to make match stick holders. It is still used today, moulded into pipe stems, and mouthpieces for musical instruments.

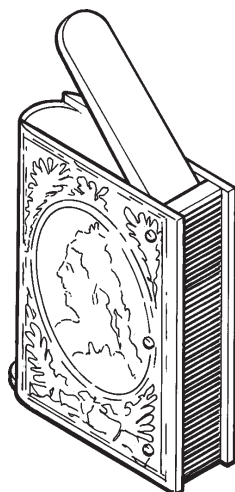

Vulcanite match
stick case

Bois Durci, which is made of cellulose in the form of finely ground wood blended with albumen from cows' blood was patented in France in 1855. It was compression moulded in a heated mould and often used to make ornate plaques which were inlaid into furniture.

In the nineteenth century manufacturing meant huge increases in the mass production of goods. A rapid increase in population, a general improvement in the standard of living and the growth of towns and cities brought with them an increased desire for material goods, especially as status objects. As traditional crafts were superseded by mechanisation (making things by machines instead of by hand) and the volume of production increased, new materials were needed to replace expensive natural materials like horn and ivory.

In 1862 a material called Parkesine was exhibited at the Great International Exhibition in London. It caused a lot of interest as a plastic material that could be used to make high quality products. It could be repetitiously moulded, in colours, and with a finely detailed surface. Its inventor, Alexander Parkes, had made it by dissolving cellulose in the forms of wood flour and cotton waste in nitric acid, thereby making cellulose nitrate. In 1866 Parkes set up a manufacturing company, but he could not control the quality of the product due to its brittleness and was forced into bankruptcy.

AN INTRODUCTION TO POLYMERS

Cellulose nitrate was first adopted commercially in America in 1869 where the Hyatt brothers made a much more mouldable version of it by mixing the cellulose nitrate with camphor. Cellulose nitrate was given the trade name of 'celluloid' and as ivory was in short supply at the time one of its first uses was the manufacture of billiard balls. However it was soon discovered that celluloid made from cellulose nitrate was explosive, and when you banged the billiard balls together they sometimes blew up! Celluloid made from cellulose acetate was developed to overcome this problem, and this is still used today in the manufacture of table tennis balls. Very large quantities of celluloid products were made for the American and European markets and the material became the first of the mass produced plastics.

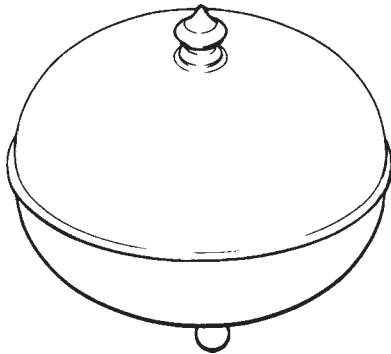

Celluloid face powder pot

In 1907 a Belgium chemist living in America called Leo Baekeland, developed the first truly synthetic plastic called phenol formaldehyde, much better known under the trade name of 'Bakelite'. Bakelite was used initially in electrical goods but soon began to appear in other consumer products. Since it was brittle it was strengthened by adding wood dust to it, which is why much early Bakelite is brown in colour. This process of adding other materials to plastics, (called fillers), to give them strength is an important part of plastics technology today. Bakelite was an enormously popular material for domestic products as it was relatively cheap and easy to manufacture and gave a consistently high quality product. Many Bakelite products were made that still survive today.

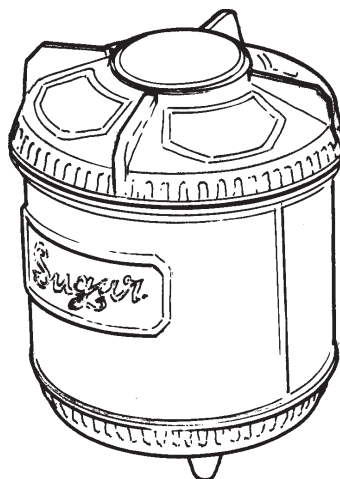

Bakelite sugar jar

AN INTRODUCTION TO POLYMERS

The early developments in polymer technology occurred without any real knowledge of the molecular theory of polymers. The idea that the structure of polymers in nature might give an understanding of plastics was put forward by Emil Fischer, who in 1901 discovered that natural polymers were built up of linked chains of molecules. It was not until 1922 that the chemist Herman Staudinger, proposed that not only were these chains far longer than first thought, but they were composed of giant molecules containing more than a thousand atoms. He christened them 'macromolecules', but his theory was not proved until 1938 when the first plastic was created with a predictable form. This was the first synthetic fibre, nylon.

As metal replaced wood in many consumer products, plastics were developed as an even cheaper alternative. The cost of casting metal increased sharply after World War II, while plastic could be formed relatively cheaply. For this reason plastics gradually replaced many things that were originally made in metal, particularly casings for products. In the 1930s, Bakelite's easily mouldable properties were ideal for designers looking for new materials for cheap domestic products. They wanted a material which could be mass produced cheaply, yet still produce stylish products. Now even luxury items, such as cigarette cases and bangles which had previously been made from ebony or ivory, could reach the mass market.

A HISTORY OF PLASTICS INVENTION

Semi synthetic plastics

- 1844** Hancock in England and Goodyear in USA perfect the vulcanisation of rubber by mixing it with sulphur. Vulcanite products appear.
- 1854** Samuel Peck produces union cases for photographs by mixing shellac and wood filler and compression moulding the mixture.
- 1862** Parkes exhibits Parkesine, made from cellulose nitrate, at the Crystal Palace International Exhibition.
- 1868** The Hyatt brothers in America produce celluloid from cellulose nitrate mixed with camphor. This is unstable and leads to the development of cellulose acetate. They develop many of the first plastics mass production techniques such as blow moulding, compression moulding and extrusion.
- 1869** Spill takes over rights to manufacture Parkesine in England and establishes the Xylonite company producing Xylonite and Ivoride.
- 1897** Spitteler in Germany patents casein marketed as Galalith and made from protein from milk mixed with formaldehyde.

Synthetic plastics

- 1907** June 20th. Leo Baekeland produces phenol formaldehyde, the first truly synthetic plastic, which comes to be known as Bakelite. Compression moulded with fillers this gives the classic Bakelite mottled product. Cast with pigments to resemble onyx, jade, marble and amber it has come to be known as phenolic resin.
- 1912** Klatte patents the manufacturing process for Polyvinyl chloride (PVC).
- 1924** Rossiter produces urea thiourea formaldehyde, marketed as Linga Longa or as Bandalastaware by British Cyanides.
- 1927** Rohm in Germany tries to stick two sheets of glass together using an acrylic ester. Accidentally he discovers safety glass.
- 1930** The Catalin corporation produce catalin or marblette, a refined phenolic resin often opaque, marbelised, translucent or richly coloured. It becomes a favourite material of art deco product designers.
- 1933** ICI (almost by accident) discover polyethylene, marketed as polythene
- 1935** DuPont make hexamethylenediamine, which they decide to rename nylon.
- 1936** Polymethyl methacrylate (Acrylic) is commercially produced by ICI
- 1936** The Wulff brothers in Germany produce Polystyrene commercially
- 1937** Otto Bayer patents polyurethane
- 1938** Plunkett working for DuPont accidentally discovers Polytetraflouroethylene, PTFE
- 1943** Silicone
- 1948** Acrylonitrile butadiene styrene (ABS)
- 1953** Expanded polystyrene
- 1954** Natta and Ziegler in Italy make polypropylene
- 1965** Stephanie Kwolek working for DuPont develops kevlar from aramide fibre
- 1958** Polycarbonates are put into mass manufacture
- 1987** BASF in Germany produce a polyacetylene that has twice the electrical conductivity of copper.

AN INTRODUCTION TO POLYMERS

THE DEVELOPMENT OF PLASTIC PRODUCTS

During the 1920s plastics became an increasingly widespread material for use in the manufacture of domestic products, including everything from manicure sets to ear trumpets and fountain pens. In 1929 Raymond Loewy, the American designer, used Bakelite to transform the old, industrial looking Gestetner duplicator into a sleek, streamlined product.

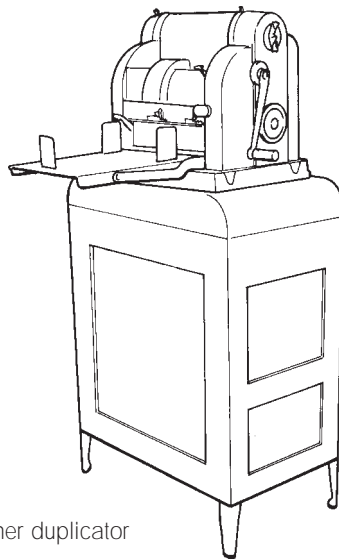

Gestetner duplicator

Radio cabinets soon became an obvious medium for plastics even though they were difficult to mould and shape, requiring huge presses. The advantage was that in the 1920s radios were new products without an established identity and plastic cases were therefore more readily accepted.

Wells Coates' circular Bakelite radio, designed for Ekco in 1934, was a radical design, and used the versatility of Bakelite as a mouldable material. Ekco was a major influence in British plastic design and designers such as Wells Coates, Serge Chermayeff and Misha Black demonstrated how plastics could start having an identity of their own instead of simply substituting for other materials.

In August 1929 the research section of the General Post Office was asked to design a small telephone. This project led to the development of the GPO 162, a wonderful, sculptural yet functional telephone that could only have been made out of plastic, and became the model for telephone design for many decades.

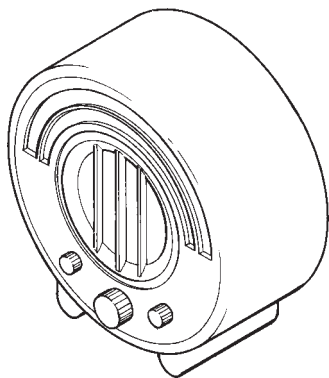

Ekco radio 1934

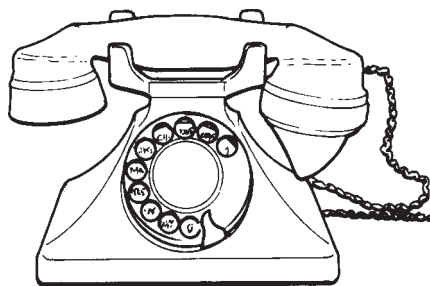

The G.P.O.
162 telephone

The period between the two World Wars has become known as the 'poly era' with the development of some of the most important plastics. In the early 1930s the American chemical company Du Pont produced the first synthetic fibre, nylon 66, whilst at the same time in England ICI, after three years research, produced probably the most common of all plastics found today, polyethylene (known as polythene).

During the second world war plastics became important and very secret materials. The properties of polyethylene were vital to the wartime development of radar as was polymethyl methacrylate, another important ICI development more commonly known as acrylic or by its trade name of Perspex. The shatter-resistant properties of acrylic when laminated with special resins were ideally suited for use as protective screens, and especially aircraft canopies.

DESIGNING WITH PLASTICS

There have really been three phases in the use of plastics in product design. Early designers using plastics either tried to invent new products (sometimes very strange ones like non-smoking ashtrays) but more often copied existing products made originally in other materials such as ebony, alabaster, onyx and amber. This meant that for the first time previously expensive products were affordable by more people. However this copying process also led to most people thinking that plastics were just a cheap substitute for real materials.

The second phase in the use of plastics during the 1940s and 1950s was the mass production of large volumes of cheap, badly made, badly designed, products, often through a manufacturing process called injection moulding. This gave plastics a reputation for poor quality goods. Although there were many plastics goods made which were well designed and of very good quality, by the end of the 1940s the word 'plastics' had come to many people to mean cheap and nasty.

In the 1950s modernist designers began to look again at plastics to produce the new kinds of products that fitted into their idea of a modern world. At this time Gino Colombini working for the Kartell design group in Milan designed a range of everyday domestic objects, such as vegetable baskets, which were very well designed and made to a very high quality. This was one of the starting points for post-war designers who believed that plastics could be used well and as materials in their own right.

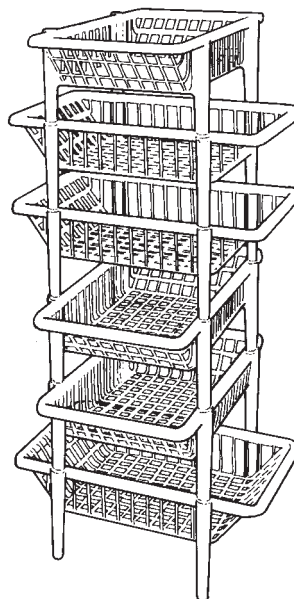

AN INTRODUCTION TO POLYMERS

One of the major successes in exploiting the virtues of plastic was the invention in 1949 of Tupperware. Earl S. Tupper, an American manufacturer, used polyethylene to create inexpensive and lightweight food containers. The key to the success of Tupperware was the resealable lid which utilised the elasticity and flexibility of polyethylene.

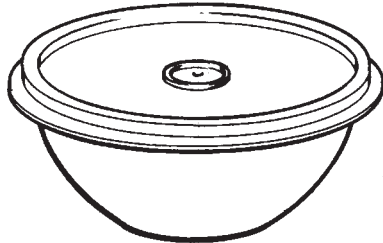

Tupperware

The early 1950s saw the introduction of plastics which were tailor made materials to fit special requirements. A tougher form of polythene called high density polyethylene (HDPE) was developed and in 1954 polypropylene was introduced. These materials were developed specifically for their material properties, and designed and made in a predetermined way, and nowadays individual plastics are still being developed which may be stronger than steel, withstand high temperatures, be used as glues in resin form or even conduct electricity.

The 1960s-1980s saw the development of composites, a new generation of lightweight, yet immensely strong structural materials. Polymer based composites are polymer resins mixed with fibres. The length and material of the fibres alter the nature of the material, for example, glass fibre is flexible whereas carbon fibres are stiff. The defence industry was the main developer of composite materials with the need for light, high performance materials which could withstand the demands of high speed flight.

Rolls Royce was using glass-reinforced polymer (GRP) compressor blades in the late 1960s and carbon fibre reinforced polymer fan blades in the early 1970s.

The use of plastics has been an important part in the history of engineering and product design in the twentieth century. They have given us the ability to develop a range of products in a very wide number of areas, from light-weight unbreakable containers, safe hygienic toys and inexpensive household objects to artificial limbs and life saving medical equipment.

PLASTICS PRODUCTION

Most modern plastics are derived from natural materials such as oil, coal and natural gas with crude oil remaining the most important raw material for their production. The starting point for the production process is the distillation, in petrochemical refineries, of the raw material into fractions (different parts). The heavy fractions give us lubrication oils and the heavy oils used for heating fuels. The lighter fractions give us gas, petrol, paraffin and naphtha. The chemical building blocks for making plastics come mainly from naphtha.

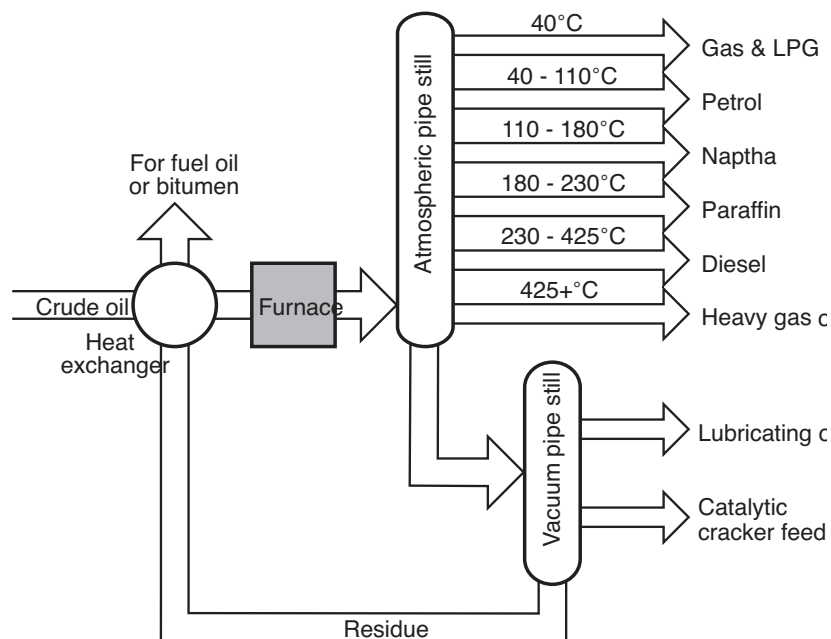

The start of making plastics is to subject naphtha to a cracking process in which complex organic chemical compounds are separated into smaller molecules, dependent on their molecular weight. These smaller molecules include ethylene, propylene, butenes and other hydrocarbons. The compounds produced through the cracking process are then further refined to produce the base plastic materials.

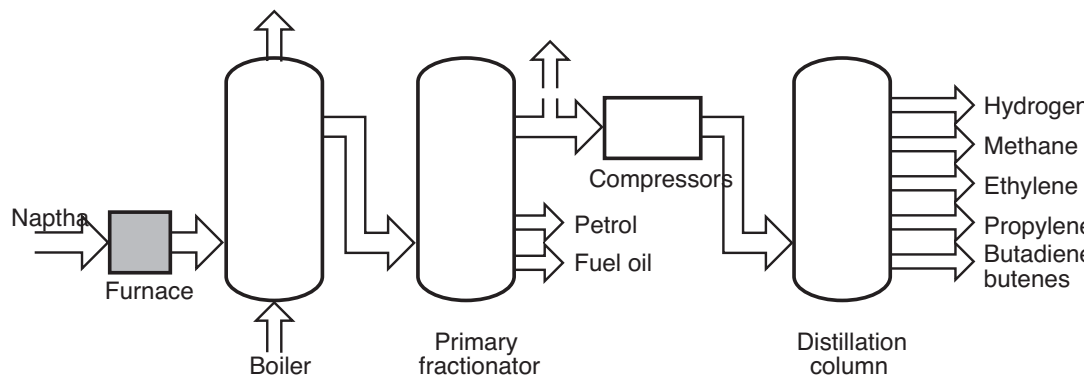

AN INTRODUCTION TO POLYMERS

THE STRUCTURE OF POLYMERS

To understand how plastics are made, and why certain plastics are suitable for some uses, and others not, you have to understand a little about the structure of polymers. Polymers are large molecules made up of many smaller molecules. 'Poly' means many and 'mer' means units. These smaller units are called monomers (mono = one, mer = unit) and are joined together through polymerisation to form polymers. A polymer contains hundreds of thousands of monomers.

Polymerisation, which means the linking of monomers to form polymers, results from two kinds of chemical reaction called condensation and addition. Polymers fall into two distinct groups, thermosetting plastics and thermoplastics. Thermosetting polymers are converted into their final form by heat and once set cannot be softened by further heating. Thermoplastics however are softened and become fused or 'plastic' by moderate heating and then harden again on cooling. This process can be repeated many times without radically altering the thermoplastic properties.

In a monomer atoms are joined by double bonds, and these must be broken and new bonds created between adjacent atoms to form the long chain molecules of a polymer through polymerisation.

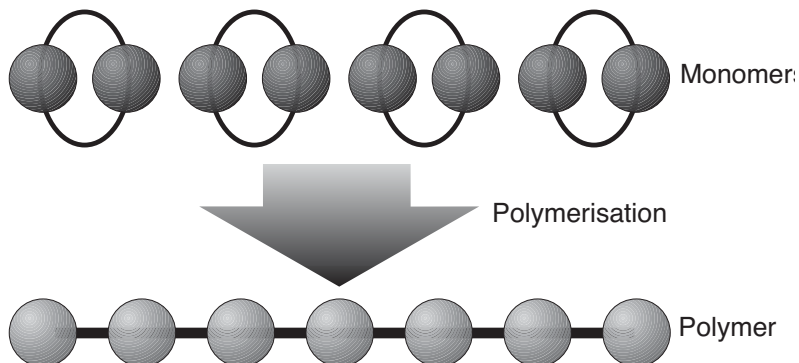

If the chains run parallel to each other the structure is said to be crystalline (made of crystals). This contrasts with the disorder of tangled chains in an amorphous (shapeless) structure. Many polymers have both crystalline and amorphous regions, and the proportion of crystalline and amorphous regions in a polymer depends on its chemical composition, molecular arrangement and how it has been processed. Crystallisation is one of the two principles that have been used to produce strong, stiff polymers (e.g. polythene and nylon), the other is the formation of strong bonds between the chains which is a process known as cross linking.

Polymers such as Bakelite and urea formaldehyde have many strong cross links which do not soften with increased heat, but set once and for all after their initial moulding. This is how we get the 'set' in thermosetting. These plastics remain comparatively strong until over heating leads to a breakdown of the cross links and chemical decomposition. By contrast in thermoplastic polymers only weak forces hold the chains together and these materials can be softened by heating and if necessary remoulded. On cooling they recover their original properties and retain any new shape.

MODIFYING POLYMERS

Polymers are initially produced as powders, granules or laces (like straws). However they are seldom used in their pure form but are changed by adding other materials to give them their special properties. For example, they may need to be resistant to sunlight, or very flexible or cheap. By using different types of additive the properties of the base polymer may be modified in very many different ways so that the range of use of the base polymer is extended. Some of the possible additives are:

- *Blowing agents*

Many plastics products are cellular in structure. If you look at them closely they look like a chocolate Aero bar. These expanded or foamed products can be made from base polymers by the addition of what are known as 'blowing agents'. This is done in the moulding process by adding a filler which foams throughout the hot polymer filling it with bubbles. A good example of this is expanded polystyrene.

- *Colourants*

Plastics can be coloured by using either dyes or pigments. Dyes give transparent colours and pigments give opaque ones. A very wide range of colours can be obtained from clear to opaque black with a naturally clear material such as acrylic.

- *Fillers*

The term 'filler' is a name given to a range of materials that are added to polymers in order to modify their properties. They may also be added to a base polymer to lower the manufacturing cost of a product made from it. A good example of this is one of the first examples of the use of fillers, adding wood flour to phenol formaldehyde.

- *Protective agents*

Many plastics are degraded by heat and light, especially from the ultra violet light in sun light. You may have seen evidence of this by plastics being 'bleached' by the sun. Adding protective agents will stop this. A special form of polyvinyl chloride is called UPVC (unplasticised PVC) which is used in the manufacture of drainpipes so that the pipes do not degrade in the sunshine.

- **Impact modifiers**

Some plastics are designed to have great impact strength; the ABS used in the manufacture of car bumpers for example. Impact modifiers are polymers that when added to other polymers improve the impact resistance of a product. Impact modifiers, based on acrylic polymers, are used in conjunction with PVC in order to get clear rigid bottles with good impact strength.

- **Lubricants**

These additives are widely used to help plastics flow in moulds. They are usually waxy materials which act by reducing the stickiness of the plastic on the mould surface.

- **Plasticisers**

Plasticisers, such as dioctylphthalate are added to polymers in order to make the resulting materials more flexible. They make plastics more plastic. Plasticisers can change unplasticised polyvinyl chloride (UPVC) from a hard, rigid material suitable for drainpipes into a soft, flexible material suitable for upholstery.

PLASTICS PROCESSING

Because of the properties of polymers it is possible to mould them and change their shape using a number of different repetitious manufacturing processes. The most important of these are extrusion, injection moulding, blow moulding, vacuum forming, extrusion blow moulding, rotational moulding, calendaring, foaming and compression moulding.

Extrusion

Extrusion is a process that can be compared to squeezing toothpaste out of a tube. Thermoplastic granules are forced through a heated barrel and the fused polymer is then squeezed through a die which is the profile of the extruded component. The extrusion is cooled by water or air as it leaves the die and is finally cut to the required length. The shape of the die can be varied from a simple hole with a centrally supported core to produce tubes such as pipes, to very complex sections for curtain tracks or hollow window frames.

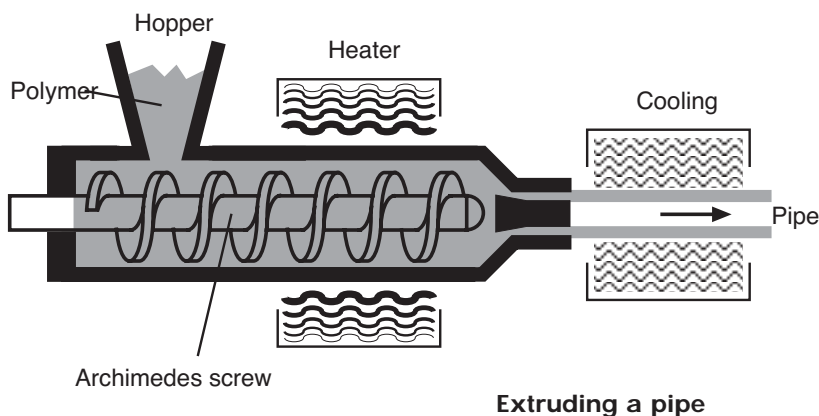

Blow moulding

Blow moulding is a simple process in which compressed air is introduced underneath a warmed sheet of thermoplastic material forcing the material into a mould cavity, or allowing it to expand freely into the shape of a hemisphere. It is a good way of forming large domes, which when made out of clear acrylic sheet are often used in shop displays.

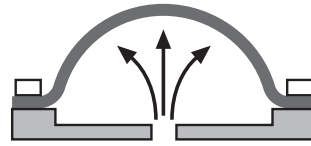
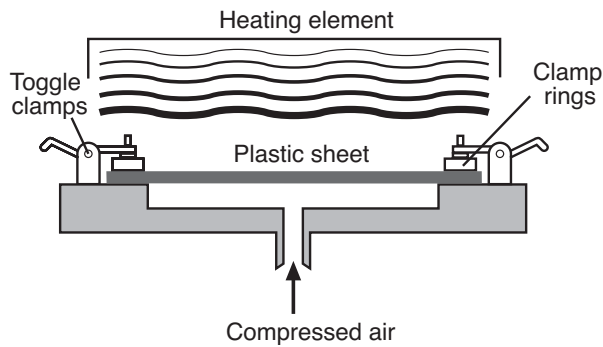

Free blown form

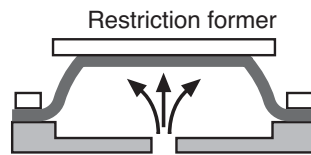

Restricted form

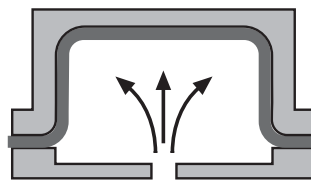

Blowing into a mould

Vacuum forming

This is a very common manufacturing process used, for example, to make a range of plastics packaging. Think of the boxes sandwiches come in, or the inner in a chocolate box, or your acrylic bath. It is really the opposite of blow moulding. Instead of the warmed plastic sheet being forced into a mould by air pressure, in vacuum forming the air is drawn out from under the softened plastic sheet, so it is forced over or into a mould by atmospheric pressure. Vacuum forming is a very common and effective way of producing complex shapes in thermoplastic sheeting.

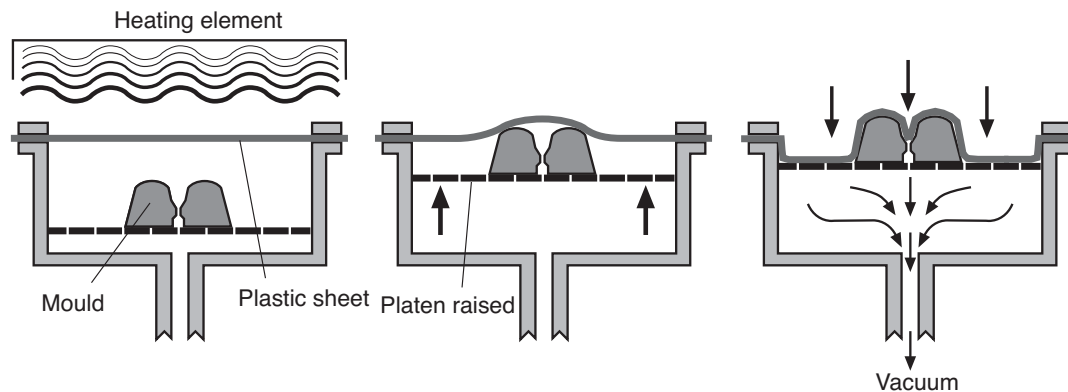

Extrusion blow moulding

This is a combination of extrusion and blow moulding and is often used where the article to be made has a narrow neck, such as a bottle. The plastic material is first extruded as a tube shape into an open die. The die is then closed to seal the ends of the tube and air is blown in forcing the plastic tube to take up the shape of the die cavity. As the material is extruded first and then blow moulded, the process is known as extrusion blow moulding.

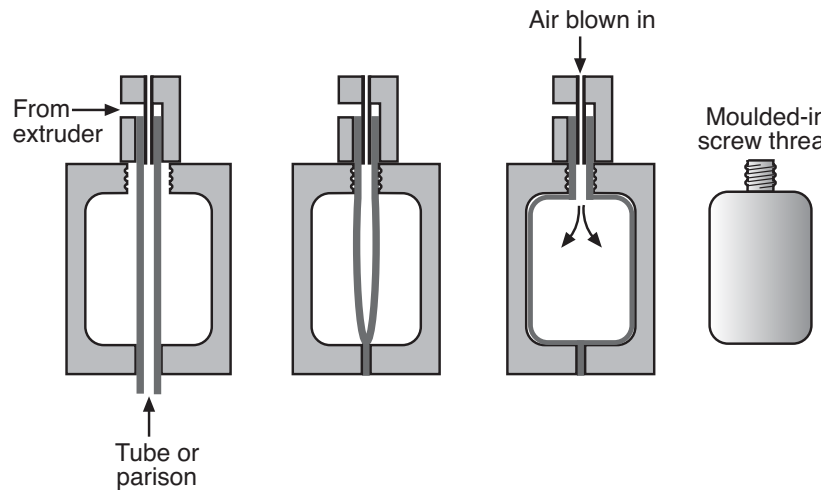

Injection Moulding

This process is one of the most common of all plastics manufacturing processes. The polymer, in granule form, is heated until fused and forced into a closed mould. Because of the viscous (thick, syrupy) nature of the fused polymer, very high pressures are needed to make it flow, which means that the machine and mould have to be very strong to withstand the forces involved.

A typical industrial injection moulding machine uses a screw to force the granules along a heated barrel, and when the granules become fused the screw is used as a plunger to force the polymer into the mould. The moulds are usually made from high grade steel to withstand the forces involved and must also be highly polished to produce a very good finish on the product, as any scratches will show up in the moulded plastic surface. Because of the ability of the plastic to show even the smallest of marks very fine detail can be cut into the surface of the mould, for example in the form of trade marks, lettering or textures.

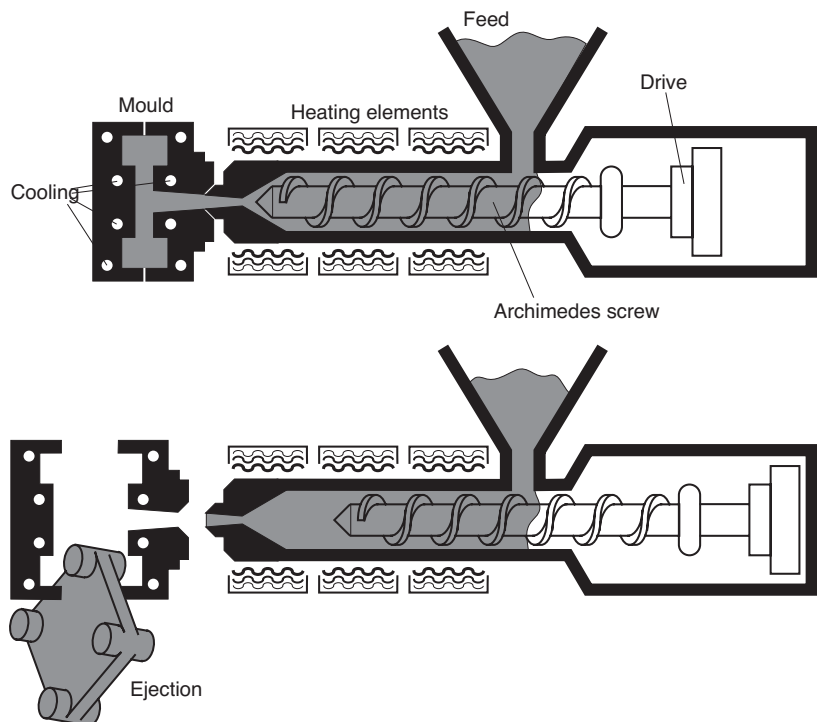

Rotational Moulding

Rotational moulding is used to produce hollow thermoplastic products such as drums, storage tanks and litter bins. A carefully calculated amount of plastic is placed in a closed mould which is heated in an oven and rotated slowly around both the vertical and horizontal axes. The plastic material fuses and sticks to the hot mould surface, building up the required thickness. The mould is then gradually cooled by air or water while still rotating. The mould is opened, the finished product removed and the mould reloaded and closed for the next cycle. The time it takes to make one of the product is known as the product's cycle time.

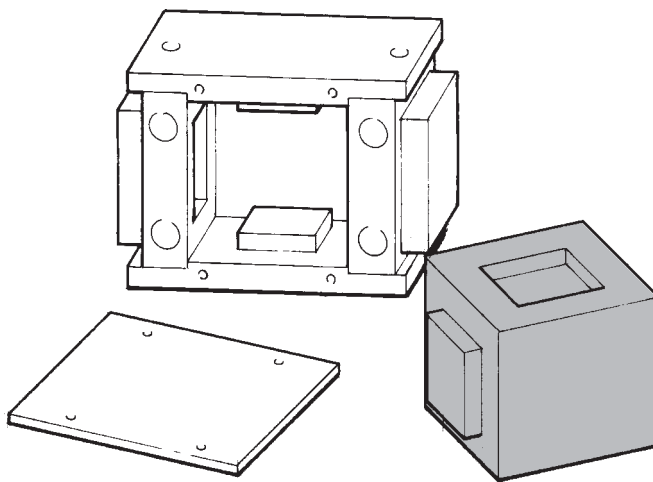

Calendering

Calendering is used to produce plastic sheeting and products such as floor tiles, coated fabrics and coverings for car interiors. Fused thermoplastic is extruded on to heated rotating rollers which squeeze the material into a continuous sheet or film. The film is cooled by jets of air or water before being cut to suitable lengths or loaded onto rolls.

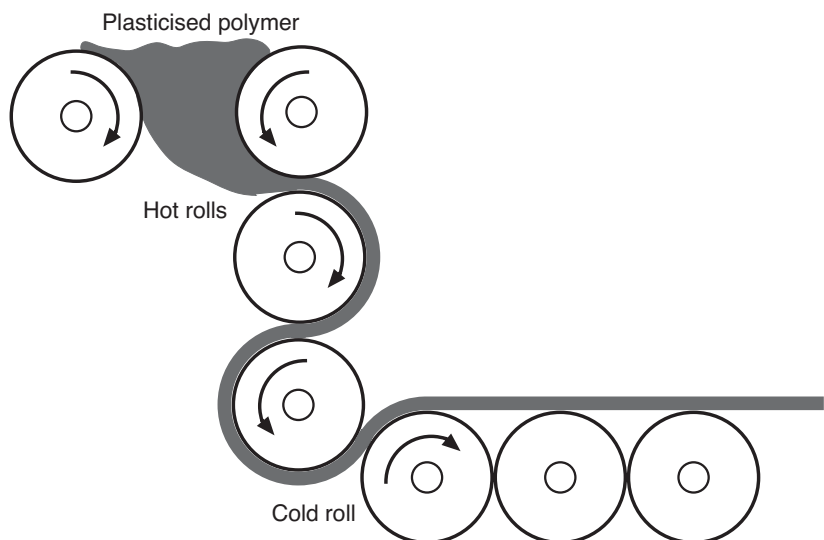

Foaming

Plastic foams used in packaging and the upholstery industry can be produced by using blowing agents which are mixed with the base polymer. When heated these agents release gas which form bubbles in the plastic. Another method is to inject compressed nitrogen gas into molten plastics during the moulding process. A third method is to freeze a gas within the plastics granules which then expands due in the heat of the moulding process.

Compression moulding

Compression moulding is one of the oldest manufacturing technologies associated with plastics and was used in 1854, for example, by Samuel Peck to make picture frames from shellac mixed with wood flour. The process is almost always used with thermosetting plastics. A carefully weighed amount of thermosetting polymer is placed into a preheated lower mould cavity. The mould is then closed by the placing of the upper half and subjected to further heat, and pressure provided by a press, often of several hundred tons capacity. The pressure and heat causes polymerisation and the flow of the plasticised material within the mould.

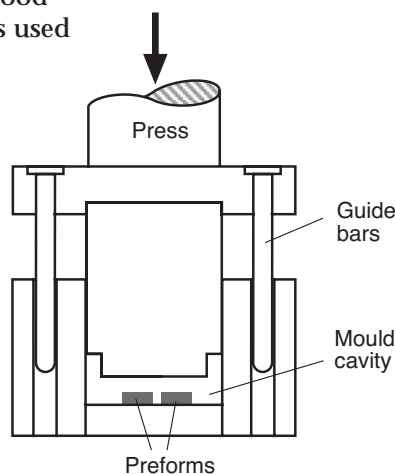

Raw thermoplastic materials containing fillers may be compressed whilst cold into small blocks of predetermined weight called preforms. Using preforms in compression moulds saves having to weigh out powdered material each time the mould is filled and decreases the cycle time, as the preforms may be preheated.

A development of compression moulding is **transfer moulding**. In this process the thermosetting polymer is first loaded into a heating chamber above the mould cavity and allowed to polymerise. It is then squeezed through channels into the mould cavity by the action of a powerful press. Transfer moulding is used when complex mouldings are required and the polymer needs to flow quickly around the mould cavity.

Many plastic articles have metal parts included within them during the moulding process. These metal parts are called inserts, and may, for example, be in the form of captive nuts used in conjunction with bolts to hold other parts of the final product assembly. The inserts are placed in recesses in the lower mould either by hand or by using loading jigs before the polymer is introduced into the mould. Compression and transfer moulding are manufacturing techniques that lend themselves to the inclusion of moulded inserts. When inserts are used the technique is often termed **insert moulding**.

PLASTICS AND THE ENVIRONMENT

There are three possible environmental problems to be considered. Firstly, plastics are mostly made from oil, natural gas or coal, and these are all limited natural resources which must be conserved. Secondly, the manufacture of plastics produces a lot of harmful pollutants which manufacturing companies need to deal with properly. Thirdly, old and unwanted plastics are not always easy to dispose of. Buried in landfill sites they will take a very long time to rot. To reduce these problems plastics must be 'designed' (for example as biodegradable), manufactured, used and disposed of considerately.

The very properties which have made plastics such a necessity to modern living may well present problems once their useful life has finished. Plastics are used as paints, cable coverings and window frames as they do not rot, and they are therefore very difficult to degrade when their useful life is over. Plastics which are used in motor vehicles are very durable and corrosion resistant which also means they are very resistant to degradation. Plastic food packaging increases the shelf life of foods, and provide a cheap, hygienic and very versatile range of wrappings. Although there are obvious advantages for the food industry, the huge increase in plastic packaging has greatly increased plastic waste, and consequently, litter.

In the manufacturing process a certain amount of waste plastics are produced as sprues and runners, (the inlets into injection moulds) and other forms of excess material. To reduce waste, this material can be reground and added back to new raw stock. Though this is possible with most thermoplastic materials, the same is not true for thermosetting materials as the addition of even quite small quantities of re-ground material can reduce the quality of the final mouldings.

Although plastic litter is very visible, the problem of plastics waste has to be seen in perspective. Plastics material accounts for only about 7% of total domestic waste. Plastic waste which does not degrade means it will not produce dangerous gases such as methane which can make landfill sites hazardous. This of course is no justification for simply dumping plastics waste and to ensure plastics are correctly disposed of alternative methods must be used.

Most plastics are made from petroleum and could be used as a fuel alternative, since many have an energy value similar to coal. Recycling by burning to produce energy would save raw materials such as crude oil and coal, and the gases produced through burning plastics are also valuable resources, which may be recycled.

An alternative way of recycling plastics is collection and reprocessing. Although recycled materials might be inferior in quality, there is still a wide range of products where the quality is not an essential factor, such as dustbin bags. The main problem with recycling plastics is their collection and sorting. Some very expensive machinery is needed to separate and wash the material, which is then granulated and reused in a range of applications similar to the original. Food packaging is an exception.

Plastics are increasingly used in the motor vehicle industry as they are light in weight, self coloured, impact resistant and readily shaped to make single integrated rather than fabricated components. The motor industries are therefore being pressured into providing recycling facilities for vehicles which have reached the end of their lives. The number of different plastics used is being reduced and those used are nowadays marked for identification. With the backing of the multinational motor companies, plastics recycling is being driven forward and new technologies are being developed which will eventually be used for domestic plastics waste.

WORKING WITH PLASTICS

Making things out of plastics is interesting and enjoyable. Plastics are colourful, warm, vibrant, light and clean and you can shape them in different ways relatively easily. Many of the skills that you learn through using timbers and metals, such as sawing and filing you can apply to plastics, and you can make some very useful attractive products quite simply. What you have to remember when using plastics is that the finish that you produce on the item is most important. When finished properly plastics products should have a good, uniform polished surface, finished badly they just look like bits of scratched plastic.

Marking out plastics

The best tool to use when marking out plastics is an engineers scribe, used against a steel ruler or try square. This will give you a good quality fine line to work to. Some people mark plastics by using felt tipped pens, but the mark from a permanent pen will need to be removed with white spirit, and a non permanent pen will rub off on your fingers.

Cutting plastics

1. Sawing

There are a number of saws that will cut plastics, but some work much better than others. Hacksaws and junior hacksaws will work but being really designed to cut metals their teeth are very fine and sometimes they will jam when cutting through thick sheet plastic. Coping saws will work, but in general they have wood blades in them and are really too large toothed for the harder plastics. They are difficult to get started and may jam in the saw cut, especially if you are trying to cut curves. Tenon saws really are designed for cutting timbers and should not be used on plastics. Probably the best saw to cut plastics with is an Abra file.

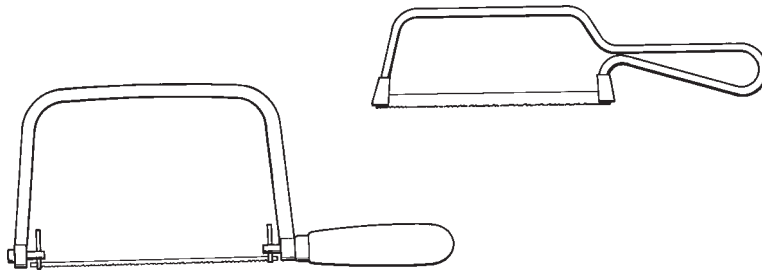

These fine toothed saws work very well and having teeth all the way around the blade means that you can cut in any direction.

2. Scoring and breaking

It can be dangerous to score and break hard and brittle plastics such as sheet acrylic. Particles of material from the broken edge may fly off at random, causing injury. However, some softer plastics sheet, such as styrene may be accurately and safely 'cut' in this way. To score the surface of styrene use a sharp engineers scriber against a metal ruler, or a craft knife against a safety ruler.

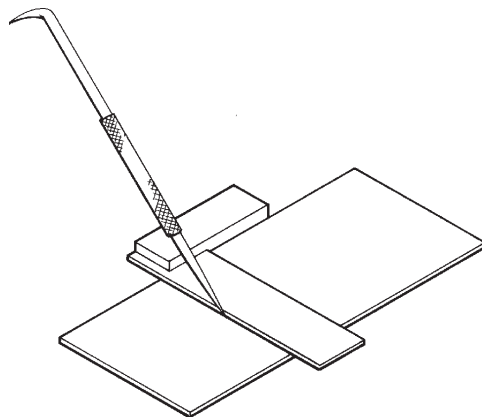

Remember: you are not trying to cut through the sheet but just weakening the surface so that it will break exactly where you want it to. Having scored the surface of the styrene stress the material along the scored line over the edge of a table or bench. The material will quickly reach its yield point and break.

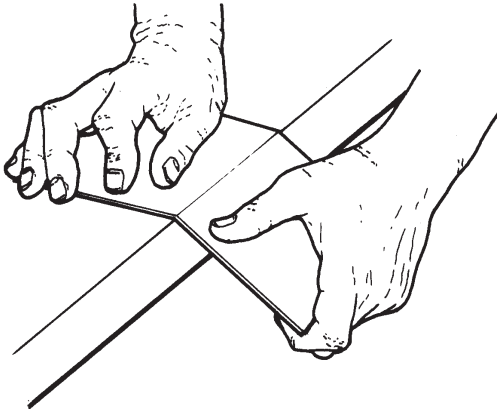

Use plastics safely;

- * When you are sawing plastics try to put the part that you are sawing as near to the jaws of the vice as possible, otherwise the material will bend as you push the saw backwards and forwards, and may well break.
- * When sawing plastics you create dust. Use a hand brush to brush this into a bin or onto the workshop floor. Do not try to blow it off the bench, it may well go in your eyes, and is very difficult to get out.

Filing plastics

Plastics are generally softer materials and are best filed using smooth or dead smooth files. Coarse files will tend to tear up a plastic's surface. Filing is a skill that requires concentration. Do not push down too hard on the file, and keep watching what is happening to the material.

You can file the edge of a piece of sawn plastic in exactly the same way as you would file a piece of metal. You will firstly need to cross file it, holding the file correctly and making it go across the material - following the form of the shape that you want to create. Stand at ninety degrees to your workpiece and as if you were taking a step forward. It is important to be in balance. Check regularly to see how you are doing, plastics are soft and you can easily file off too much.

When you have filed across the workpiece you can draw file it. For this you will need to change your grip on the file, and the position that you are standing in. Draw filing changes the direction of the scratches on the surface of the plastic made by cross filing. Draw filing will give fine scratches that run parallel to the edge of the material. After you have drawfiled check that all the scratches are going in the same direction and that the surface is smooth. Cross filing and draw filing are the start of the process of polishing.

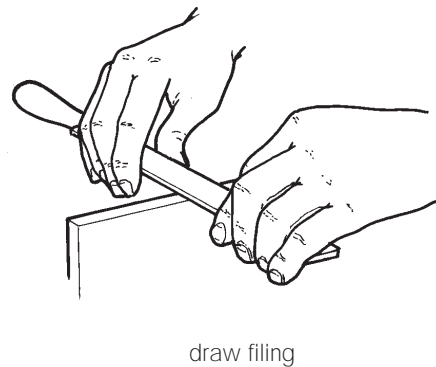
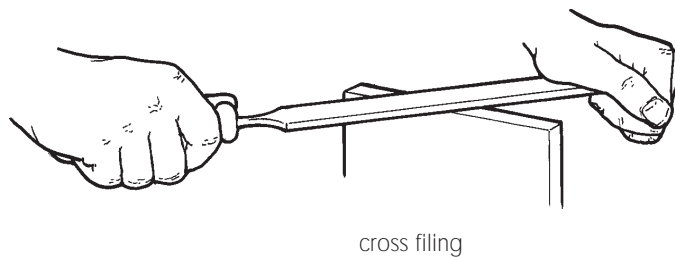

Finishing plastics

It is very important that everything that you make out of plastic has a very high quality finish. This means that all the edges you have sawn and filed have to be smooth and possibly highly polished. (There is actually no such thing as a polished surface. There are just surfaces that have such tiny scratches in them that we cannot see them with the naked eye. If you look at them under the microscope you will see plenty of scratches).

Using abrasive papers

To reduce the depth and size of the scratches that the cross filing has produced we use abrasive papers, either emery cloth, or more preferably wet and dry paper. These abrasive papers are manufactured with different sized silica carbide grits stuck to them. The different sized grits produce different depths of scratches so it is fairly obvious that you have to use the abrasives in order, coarsest first and the finest last. You can tell the different sizes of grit on abrasive papers by reading the numbers printed on the back of them. Some common grit sizes are 120, 220, 400, and 600. The lower the number the larger the grit size.

The best way to use wet and dry paper is to stick a full sized sheet down onto an A4 sized piece of scrap plywood. This allows you to rub the plastics material onto a firm, flat surface, and is a very controllable way to smooth straight edges. For shapes other than straight edges wet and dry paper can be wrapped around a small piece of scrap wood, or a cork sanding block. It is really quite difficult to smooth plastics accurately and controllably holding abrasive papers in your hand.

Remember: always use wet and dry paper wet with water when smoothing and polishing plastics as the water will act as a lubricant and give a better quality surface. Do not wet emery cloth; it disintegrates when wet.

After you have worked through a number of increasingly fine wet and dry papers you should find that your work has a reasonably smooth surface. This can be finished to a high quality polish by using a rotary polishing machine, or polishing by hand. A number of different types of polishes can be used for hand polishing. Tensol numbers 1 and 2 are made especially for plastics, but Brasso or Duraglit and other fine metal polishes will work, as will toothpaste. What all these polishes have in common is that they contain very small particles of grit that create scratches the eye cannot see.

The buffing machine

The buffing machine is used to put a final polish on plastics and metals. It consists of round, calico mops mounted on a spindle and driven by an electric motor. It is best if mops used for polishing plastics are not mixed with ones used for polishing metals. Polish in stick form is loaded onto a mop when it is rotating. Always wear goggles when buffing as polish and other debris is thrown off of the mop.

The buffing machine appears to be very simple to use, but in fact it is a common cause of accidents, often resulting in the work being damaged rather than the machine operator. When you are using this machine make certain that you remember to concentrate. And remember to observe all of the aspects of personal safety. You should be wearing protective glasses or goggles and an apron, loose hair should be tied back, you should roll your shirt or pullover sleeves up and be sure that you have no jewellery that can get caught in the rotating mop.

People often have accidents when using buffing machines because they forget the direction that the mop is turning in. It turns towards you. This means that the work has to be offered up to the bottom of the mop. If you use the top of the mop the workpiece will 'catch' and it will be pulled from your grip and thrown onto the floor. When you are polishing a length of plastic material start in the middle of an edge and work the material towards you. Do not press too hard, plastics are soft and will easily be worn away by the mop's abrasive action.

Look at the illustration and you will see the position of the material on the mop.

Remember, a polishing mop will not polish out deep scratches. It will only give a good quality polished finish on a piece of work if the material has first been worked using abrasive papers.

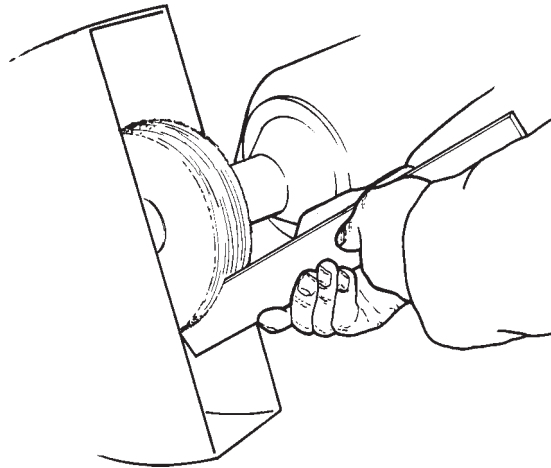

Fabricating plastics

Plastics can be bonded together using a range of adhesives, but the ones that you are going to find most commonly in your school workshop are Tensol No.12 and Plastic Weld. Be careful using adhesives. You can easily ruin your work by getting glue where you do not want it or sticking parts together wrongly. Apply the adhesive carefully, using a small amount and mask off areas near to gluing surfaces using tape. Fasten the work gently in clamps, a vice or by using masking tape, and then check that the component pieces are in exactly the position that you want them. Allow an adhesive time to fully cure (set) before doing any further work.

SHAPING PLASTICS USING HEAT

Shaping plastics using heat is termed thermoforming. In a school or college workshop acrylic sheet and styrene sheet are the two most commonly used plastics materials worked in this way. Heat can be applied to acrylic sheet using an oven or a strip heater, and to both acrylic and styrene sheet using a vacuum forming machine. When thermoforming plastics there are certain points to remember.

- * Acrylic needs to be warmed to 180°C to make it soft enough to bend and mould easily. At this temperature the material will burn your fingers so always wear asbestos-substitute gloves when handling hot sheet.
- * Sheet plastics need to be heated throughout their thickness before they can be moulded. Do not just heat from one side, or at the surface; allow the core time to warm up as well. If the core is not soft the material may tear or break when you try to form it.
- * Thermoplastic sheet is supplied wrapped in a protective layer of polythene or paper. Remove this protective layer before you do any thermoforming.

Using an oven

Acrylic sheet in an oven set at a temperature of 180°C will soften so that it becomes 'plastic', or easy to form. Acrylic at this temperature can easily be shaped freely by hand. A more controlled process is **press forming** using a former made from wood.

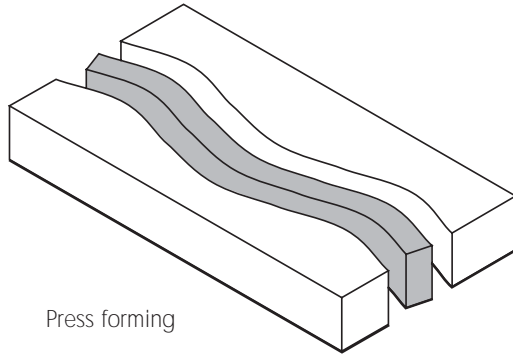

Press forming

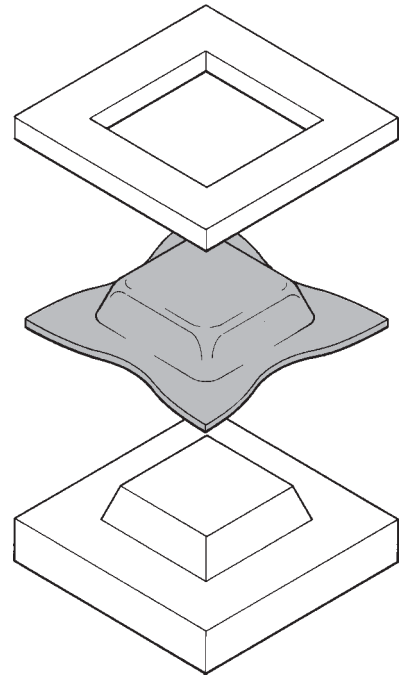

Plug and yoke forming

A simple press forming technique is the plug and yoke method, which is a good way of making dished shapes or enclosures.

Using a strip heater

A strip heater, containing an element like a one bar electric fire, is used to heat up a localised area of sheet plastics so that it can be bent in a straight line. In fact sometimes these devices are called line benders. Unlike an oven which heats the whole sheet, the strip heater only warms a given strip. Bending the sheet, for example at a right angle then becomes a very controllable process. Before using the strip heater mark where you want the bend line on your plastic. Turn the plastic over regularly on the strip heater so that both sides are heated and the core of the material also becomes softened.

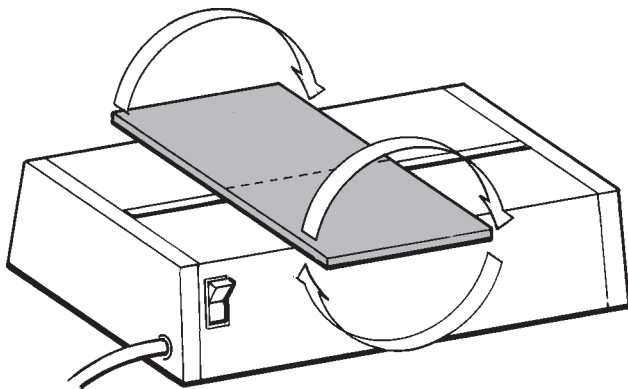

The vacuum forming machine

Vacuum forming machines are available in a variety of types and designs although they all achieve the same end. They work by creating a vacuum under a piece of heated thermoplastic sheet allowing atmospheric pressure to push the sheet down over a prepared mould. Therefore before you use the vacuum forming machine you will have to make the mould or tool. This is usually constructed from wood, and is made in the shape that you want the plastic to assume. When designing a mould remember that after vacuum forming the mould has to be withdrawn from the formed plastic sheet and to enable this to happen the mould has to be slightly tapered with angled sides. This angle is called a draft angle; 5 degrees is usually sufficient.

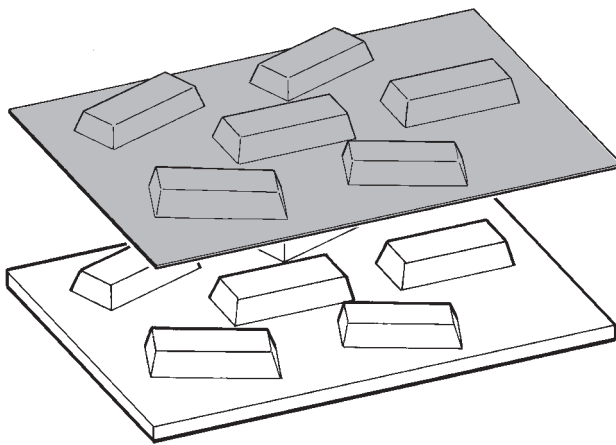

The mould must also have a high degree of finish, as any marks on it will be picked up by the hot sheet. You can polish your mould using wax polish. This helps give a good finish and also assists mould release from the formed plastic sheet.

A complete mould is placed inside the machine on a platform that can be raised and lowered. Thermoplastic sheet is then clamped to a frame and heated using electric elements. When the plastic has been heated until it has thoroughly softened the mould is raised up to it and a vacuum pump switched on. This evacuates the air from underneath the softened sheet, and atmospheric pressure forces the sheet down over the mould.

AN INTRODUCTION TO POLYMERS

TRANSFER PRINTING ONTO STYRENE SHEET

Many plastic products are printed as part of their manufacturing process. This is done by complex machinery and is not easy to duplicate in a school or college workshop. However, styrene sheet can be finished using a very simple process called transfer printing. This involves lifting the printed image off of a photocopy and transferring onto the styrene. To do this you will need;

- A fresh photocopy of the image(s) that you want to print. (Text will come out back to front unless you can photocopy it in a mirror image).
- A small bottle of white spirit.
- Some pieces of clean rag.
- A piece of styrene sheet.

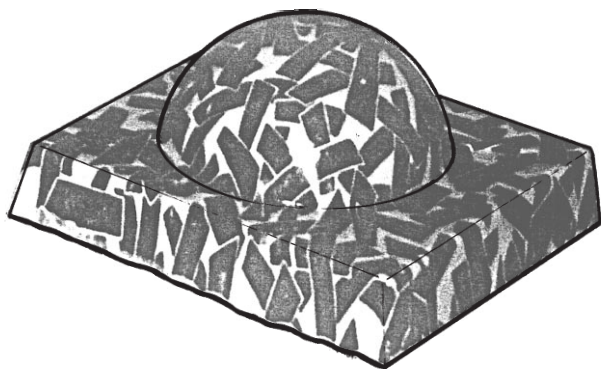

Have everything that you need to hand on a bench. Pour a little white spirit onto a piece of clean rag and wipe the white spirit onto the side of the styrene sheet that you want to print on to. (Remember to remove the protective film on the styrene sheet first). Put the photocopy printed side down onto the wet styrene sheet and putting more white spirit onto the rag, rub the back of the photocopy thoroughly all over until the photocopy is damp with spirit. Leave alone for about four minutes. After this time, gently peel one edge of the photocopy back off of the styrene and you will see the printed image transferred. If not all of the toner has lifted off of the photocopy lay it back onto the styrene and rub it slowly and firmly with the rag dampened in white spirit. With a little practice and patience you will learn to get a very good printed image.

Safety note: This process must only be carried out in a well ventilated place.

AN INTRODUCTION TO POLYMERS

COMMON PLASTICS AND THEIR USES

Thermoplastics

Acrylonitrile butadiene styrene	ABS	computer housings, car bumpers, camera bodies, telephones, suitcases
Cellulose acetate		spectacle frames, toothbrush handles, packaging film
Methyl methacrylate	Acrylic	jewellery, display stands, shop signs, lenses, synthetic fibres
Polyamides	Nylon	clothing, gears, bearings, zips
Polycarbonate		bullet proof shields, bottles, crash helmets
Polyethylene	Polythene	carrier bags, kitchen containers, children's toys
Polypropylene		furniture, ropes, electric kettles, door handles, hinges
General purpose polystyrene	GPPS	packaging, jewellery
High impact polystyrene	HIPS	refrigerator inners, radio casings, yoghurt pots
Expanded Polystyrene		thermal insulation, packaging
Polytetraflouroethylene	PTFE	bearings, plumbers tape, electrical insulation
Polyurethane		upholstery foam, skate boards, hammerheads, synthetic leather
Polyvinyl acetate	PVA	paint, wood glue
Polyvinyl chloride	PVC	drainpipes, electrical insulation, cling film
Styrene acronitrile		disposable cutlery

Thermosetting plastics

Casein		buttons
Epoxy resins	Araldite	adhesives, coatings
Melamine formaldehyde	Formica	decorative laminates
Phenolic resin	Bakelite	electrical insulators, ashtrays, saucepan handles, toilet seats
Polyester resin	GRP	glass reinforced plastics used in boatbuilding and car bodies.
Advanced polyester resin		glue gun bodies, power tool casings
Polyurethane		lacquers, car bumpers, shoe heels
Urea formaldehyde		light fittings
Thiourea formaldehyde		picnic sets, kitchen ware

SOURCES OF INFORMATION ON PLASTICS

BP Educational Service PO Box 934, Poole, Dorset BH17 7BR
Tel; 01202 669940 Fax; 01202 679326
BP produces a wide range of publications dealing with making and using plastics technology and environmental issues.

ICI Educational Liaison ICI Teeside Community Relations Group, The Grange Communications Centre, PO Box 54, Wilton, Middlesbrough, Cleveland TS90 8JA
Tel; 01642 433927
An educational information service about all ICI plastic materials.

Shell Education Service Shell UK Ltd, Shell Mex House, Strand, London, WC2R 0DX
Tel; 0171 257 3000 Fax; 0171 257 1382
Shell produces a wide range of educational materials to do with plastics including books, software, videos and films.

The British Plastics Federation 6 Bath Place, Rivinton Street, London, EC2A 3JE
Tel; 0171 457 5000 Fax; 0171 457 5045
The BPF produces books and fact sheets on all types of plastics and will tell you of companies working with plastics in your area who welcome school visits.

AN INTRODUCTION TO POLYMERS

Institute of Materials Education Department, 1 Carlton House Terrace, London SW1Y 5DB
Tel; 0171 839 4071

Materials Information Service also at the Institute of Materials, Education Department, 1 Carlton House Terrace, London SW1Y 5DB

An information service about materials including plastics.

Plastics and Rubber Advisory Service part of the British Plastics Federation

Tel; 0839 506070 Fax; 0171 457 5045

A general inquiry service about plastics.

Plastics Historical Society at the Institute of Materials, 11 Hobart Place, London SW1W 0HL

Tel; 0171 245 9555 (Tuesdays only) Fax; 0171 823 1379

A society founded to document the history and development of plastics.

The Polymer Industry Education Centre Dept. of Chemistry, University of York, Heslington, York. YO1 5DD

Tel; 01904 432560 Fax; 01904 432516

For fact sheets and books on all types of plastics plus an information service.

PLACES TO VISIT

Materials Recycling Facility, Milton Keynes which has its own education officer. Tel; 01908 22500

Science Museum Plastics Gallery The Science Museum,

Exhibition Road, South Kensington London SW7 2DD

Education Enquiries Tel; 0171 938 8222

A small exhibition of the history of plastic materials and plastics manufacturing machines.

Decodence 13 The Mall, Camden Passage, Islington, N1 0PD

Tel; 0171 354 4473

London's best plastics antique shop (Wednesdays and Saturdays only).

AN INTRODUCTION TO POLYMERS

EDUCATIONAL RESOURCES

Plastics Rapping, a video on plastics, packaging and recycling.
The British Plastics Federation 6 Bath Place, Rivinton Street,
London, EC2A 3JE
Tel; 0171 457 5000 Fax; 0171 457 5045

Plastics Packaging; safeguarding our health and environment.
A video on plastics, packaging and recycling.
The Polymer Industry Education Centre, Dept. of Chemistry,
University of York, Heslington, York. YO 1 5DD
Tel; 01904 432560 Fax; 01904 432516

Technology and Plastics a pack of videos and booklets designed
for KS3 investigating the use of plastics in the home, work and
industry. Includes design and make tasks.
BP Educational Service PO Box 934, Poole, Dorset BH17 7BR
Tel; 01202 669940 Fax; 01202 679326

Plastic Opportunities with Technology, a video for KS3/4 with
texts, tasks and information sheets investigating the uses of
plastics using the context of insulation.
SCSST, 76 Portland Place, London, W1N 4AA
Tel; 0171 278 2468

BOOKS ON PLASTICS

Sylvia Katz - Classic Plastics - Thames and Hudson - 1984

BPF - 1986 - The World of Plastics - British Plastics Federation -
1986

Penny Sparke - The Plastics Age - Victoria & Albert museum -
1990

Mike Hall - Design and Plastics - Hodder and Stoughton - 1988

Terry Cash - Plastics - HMSO/Science museum - 1991

John Brydson - Plastics Materials - Butterworth Heinemann -1995

Kay Davies & Wendy Oldfield - Its Plastic - Wayland Ltd. - 1992

Patrick Cook and Catherine Slessor - Bakelite - Apple Press - 1992

Andrea DiNoto - Art Plastic - Abbeville Press - 1971

AN INTRODUCTION TO POLYMERS

PLASTIC MATERIALS SUPPLIERS

EMA Model Supplies Ltd
58 - 60 The Centre
Feltham
Middlesex
TW13 4BH

Trylon Ltd
Thrift Street
Wollaston
Northants
NN9 7QJ

K&M Ltd
Unit 24
Lion Park
Holbrook Industrial Estate
New Street
Halfway
Sheffield

Middlesex University
Teaching Resources Centre
Trent Park
Bramley Road
London
N14 4XS